



# VESCOM

## FLOOR SYSTEM

TECHNICAL MANUAL

April 2026



# CONTENTS

<b>LIST OF FIGURES</b> .....	iii
<b>LIST OF TABLES</b> .....	iii
<b>1 The Vescom Composite Joist System Introduction</b> .....	<b>1</b>
1.1 Note to Design Teams and Users	
1.2 Purpose of the Vescom System	
1.3 Advantages of the Vescom Floor System	
<b>2 Vescom Composite Floor Components</b> .....	<b>2</b>
2.1 The Vescom System	
2.2 The Vescom Composite Joist (CJ)	
2.3 Vescom Long-span Joist (LSJ)	
2.4 Vescom Mini Joist (MJ)	
2.5 Vescom Composite Girder (CG)	
2.6 Vescom Vierendeel Composite Joists and Girders (VCJ, VLSJ, VCG)	
<b>3 Metal Deck, Concrete Slab, and Welded Wire Mesh</b> .....	<b>5</b>
3.1 Vescom Slab Design	
3.2 Metal Deck	
3.3 Floor Assembly	
3.4 Concrete and Welded Wire Mesh	
3.5 Typical Residential Slab Parameter	
<b>4 Composite Action of the Vescom Top Chord</b> .....	<b>9</b>
4.1 Composite Design	
4.2 Composite Design in the Steel Joist Industry	
4.3 Vescom Composite Advantages	
<b>5 Vescom Floor System Design</b> .....	<b>10</b>
5.1 Vescom Design	
5.2 Vescom Design Methods	
5.3 Vescom Joist Depth	
5.4 Vescom Floor Diaphragm	
5.5 Vescom Joist Spacing	
5.6 Vescom Joist Designation	
5.7 Vescom Joist Deflection	
5.8 Vescom Joist Camber	
5.9 Vescom Joist Vibration	
5.10 Vescom Special Joists (SCJ or CJ*)	

# CONTENTS [CONT.]

<b>6</b>	<b>Bearing for the Vescom Joist</b> .....	<b>14</b>
6.1	Vescom Flush Seat	
6.2	Vescom Bearing on Cold-Formed Steel Walls	
6.3	Vescom Bearing on Concrete or Grouted Masonry Walls	
6.4	Vescom Bearing on Structural Steel Columns or Beams	
6.5	Vescom Bearing on Insulated Concrete Forms	
6.6	Vescom Cantilever and Balcony Applications	
<b>7</b>	<b>Vescom UL Fire Ratings</b> .....	<b>16</b>
7.1	Vescom Fire-Rated Assemblies	
7.2	Vescom Fire Rating for Multi-Story Residential	
<b>8</b>	<b>Vescom Sound Ratings</b> .....	<b>18</b>
8.1	Vescom STC, IIC, and HIIC	
8.2	Vescom Sound Testing	
<b>9</b>	<b>HVAC Duct Penetrations</b> .....	<b>19</b>
9.1	Vescom's Open Web Construction	
9.2	Special Vierendeel Openings in Vescom Trusses	
9.3	Duct Penetrations Without Special Openings	
<b>10</b>	<b>Vescom System Erection</b> .....	<b>20</b>
10.1	Vescom Erection Advantage	
10.2	The Four (4) Step Process	
<b>11</b>	<b>Vescom Specification</b> .....	<b>22</b>
<b>12</b>	<b>Vescom Joist and Deck Erection Notes</b> .....	<b>27</b>
<b>13</b>	<b>Vescom Typical and Special Details</b> .....	<b>29</b>

## LIST OF FIGURES

<b>FIGURE 1.</b>	Anatomy of the Typical Vescom Floor .....	1
<b>FIGURE 2.</b>	Example HVAC Penetrations through the Vescom Floor System .....	1
<b>FIGURE 3.</b>	Vescom Composite Joist (CJ) .....	2
<b>FIGURE 4.</b>	Vescom Composite Joist (CJ) .....	2
<b>FIGURE 5.</b>	Vescom Long-span Joist (LSJ) .....	2
<b>FIGURE 6.</b>	Vescom Type A Composite Mini Joist (MJ) .....	3
<b>FIGURE 7.</b>	Vescom Type B Composite Mini Joist (MJ) .....	3
<b>FIGURE 8.</b>	Vescom Composite Girder (CG) .....	3
<b>FIGURE 9.</b>	Typical Vescom Joist Vierendeel Opening .....	4
<b>FIGURE 10.</b>	Typical Vescom Long Span (Girder) Vierendeel Opening .....	4
<b>FIGURE 11.</b>	Typical Vescom Floor Section Detail .....	5
<b>FIGURE 12.</b>	Joist Depth Definition .....	10
<b>FIGURE 13.</b>	Vescom Joist Depth Efficiency Graph .....	11
<b>FIGURE 14.</b>	Vescom Joist Designation Detail .....	12
<b>FIGURE 15.</b>	Typical Vescom Joist to CFS Wall Connection .....	14
<b>FIGURE 16.</b>	Typical Vescom Joist to Concrete Wall Connection .....	14
<b>FIGURE 17.</b>	Typical Vescom Joist to Wide-flange Beam Connection .....	14
<b>FIGURE 18.</b>	Vescom Joist Duct Opening Reference Sizes .....	19

## LIST OF TABLES

<b>TABLE 1.</b>	Vescom Typical Metal Deck Design with Normal Weight Concrete .....	6
<b>TABLE 2.</b>	Live Load for NW Concrete Slabs on UFX Deck (LRFD Design Method) .....	7
<b>TABLE 3.</b>	Live Load for Light-weight Concrete Slabs on UFX Deck (LRFD Design Method) .....	8
<b>TABLE 4.</b>	Vescom Fire Rated Assemblies .....	16
<b>TABLE 5.</b>	Vescom Sound Ratings .....	18
<b>TABLE 6.</b>	Vescom Joist Duct Size Table per Joist Depth .....	19



# VESCOM COMPOSITE FLOOR COMPONENTS

## 2.1 The Vescom System

Vescom is a complete composite floor system that supplies **composite bar joists, mini-joists, long-span joists, decking, and pour stops**. In addition to supporting uniform loads, the Vescom joist system can be customized to support special loads, including point loads and non-continuous linear loads.

## 2.2 The Vescom Composite Joist (CJ)

The Vescom Composite Joist is an open-web, top-chord bearing, parallel-chord steel truss in a Warren truss configuration. It is used for conventional loads spanning up to 40 feet or more. Vescom joists are made with structural steel angles and steel round rods, with all connections joined via welds. The chords of the Vescom joists are double angles, back-to-back, of various sizes, established by their required design strengths. The top chord, specifically, is a double angle with one angle having dimples to make a composite connection with the concrete slab. The webs of the joist are round bars of size established by their required design strengths.

The distance between web nodes (a.k.a. panel points) is typically 24" but can be increased or decreased for special cases.

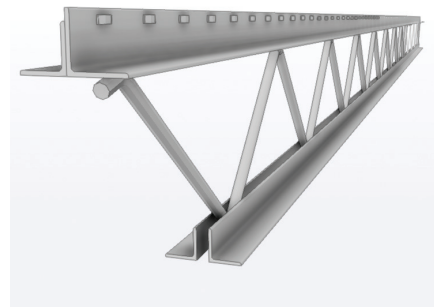

Lièl.ä. İáiyÁÁ EÁÁ ÉÁÍµá.Öúí EÓ

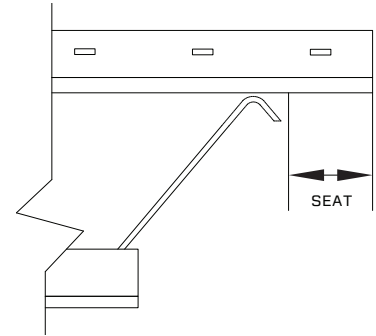
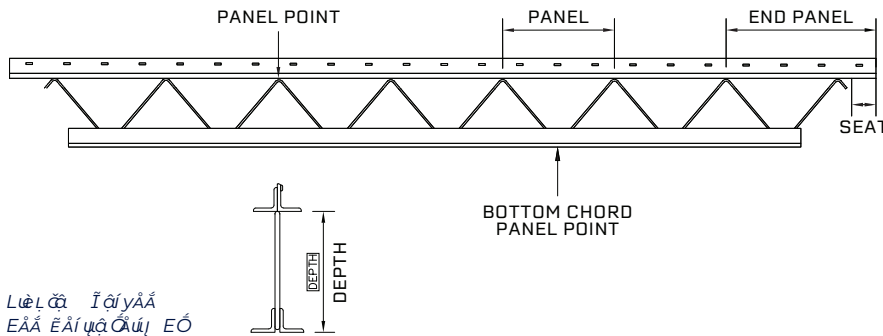

## 2.3 Vescom Long-span Joist (LSJ)

The Vescom Long-span Joist serves the same function as the typical Vescom Composite Joist but is used for longer spans and/or heavier design loads when larger web sizes are required. The difference is that the Vescom Long-span joist has single or double-angled web members and top chord gusset plates at web connections. Web panel lengths are variable and dictated by the loads, depth of joists, and sized to accommodate mechanical circulation in the plenum.

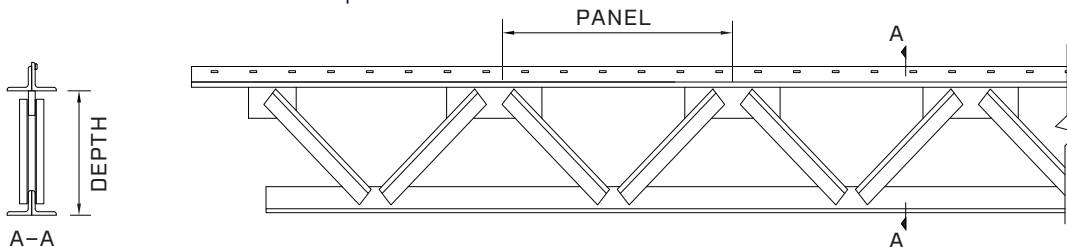

Lièl.ä. İáiyÁÁ ÖÁÁè İÉSA Öúí ÖÓ

## 2.4 Vescom Mini Joist (MJ)

The Vescom Mini-Joist is for framing shorter spans. Depending on the span and load, it can be comprised of only a Vescom top chord, or if design load and span dictate it can be a Vescom top chord with a small steel member component such as an angle, tube steel, or C-channel.

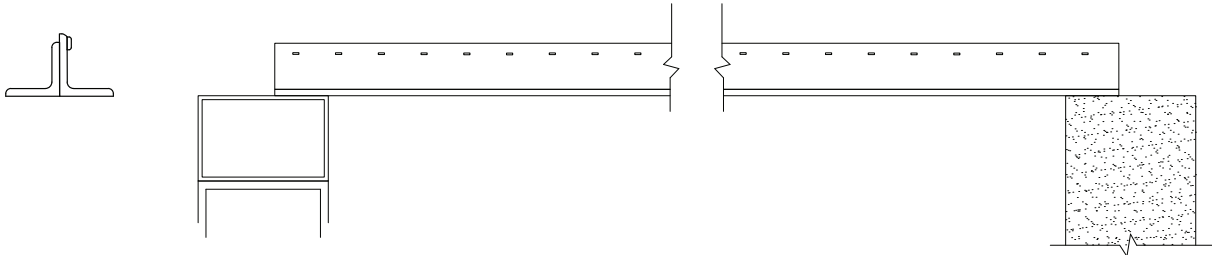

L 0 L 0 I 0 y 0 A 0 E 0 E 0 A E 0 A 0 E 0 A 0 I 0 q 0 S 0 u 0 C 0 u 0 j 0 S 0 O

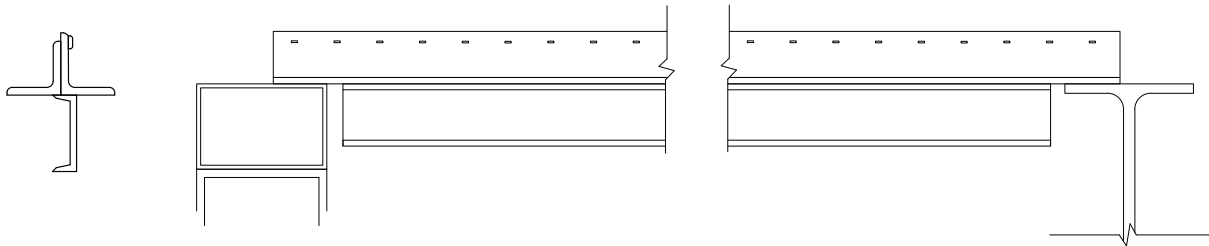

L 0 L 0 I 0 y 0 A 0 E 0 E 0 A D E 0 A 0 E 0 A 0 I 0 q 0 S 0 u 0 C 0 u 0 j 0 S 0 O

## 2.5 Vescom Composite Girder (CG)

The Vescom Composite Girder is the senior composite truss member, supporting Vescom joists, steel beams, and/or other minor framing members. Its composite connection is the Vescom double-angled top chord with dimples. It has double-angled web members and top chord gusset plates at web connections. Web panels are customizable to support the minor framing members loading the girder.

Given that the angles for both the top and bottom chords face upward, the Vescom Composite Girder trusses can be designed as part of a lateral system's moment frame with user-friendly moment connections.

When used together, the Vescom Composite Girder and the Vescom Composite Joist have an open web structure in both directions, making MEP distribution in the ceiling plenum easy.

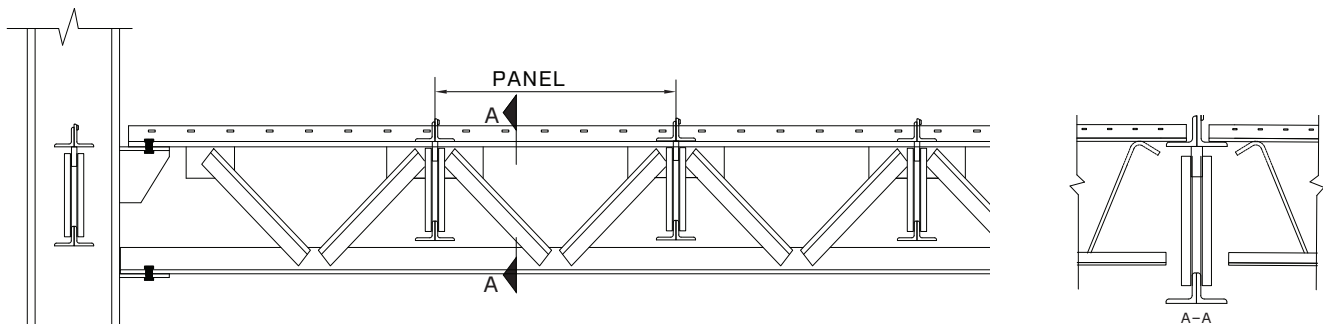

TRUSS SUPPORTED BY COLUMN [MOMENT CONNECTION]  
JOISTS ARE ONLY SUPPORTED BY THE TRUSS

L 0 L 0 I 0 y 0 A 0 E 0 A 0 E 0 A 0 I 0 q 0 S 0 L 0 u 0 z 0 q 0 E 0 L

## 2.6 Vescom Vierendeel Composite Joists and Girders (VCJ, VLSJ, VCG)

The open plenum of the Vescom Composite Joists, Long-span Joists, and Girders can be further expanded and customized with the addition of Vierendeel openings to accommodate items passing through the joist line such as, larger mechanical ducts, mechanical units, structural steel, etc.

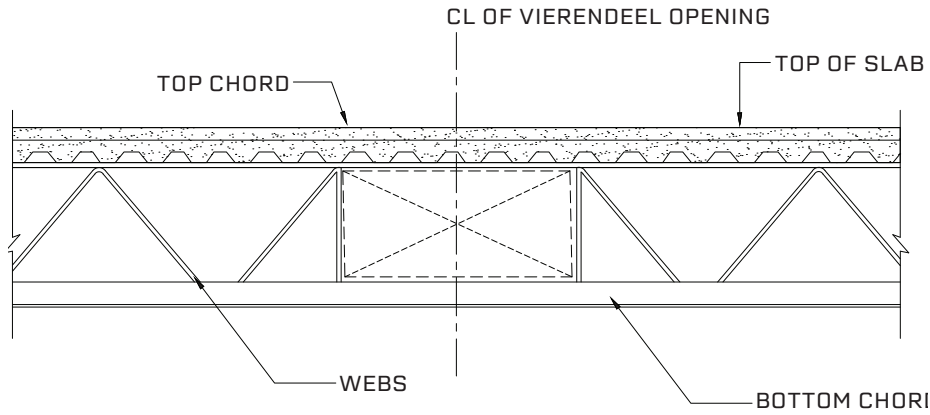

L'èl. cã ÈcÈÿs ÿÏ àÿyÁÁ Óúÿ Ì ùççÁZ ççÿË çÁùè

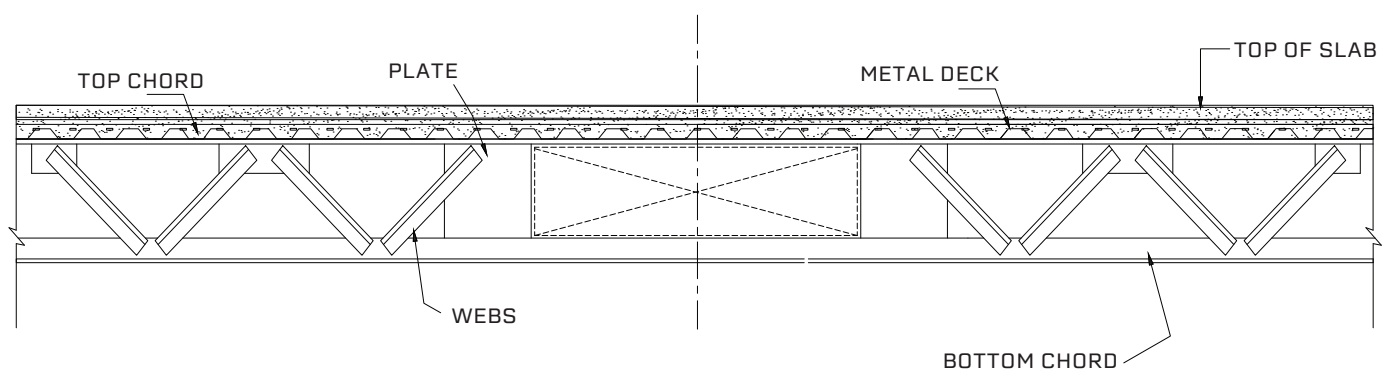

L'èl. cã ÈcÈÿs ÿÏ àÿyÁÁ Óúè ÆÈSÁ L'ùç çç Ì ùççÁZ ççÿË çÁùè



### 3.5 Typical Residential Slab Parameter

The typical residential slab features a 1 ½- or 2-hour fire rating under UL BXUV G531, with an attached ceiling. The assembly can use either regular weight or lightweight concrete.

We have set up the following tables showing the slab capacity excluding the dead load if the decking is galvanized, but it includes the dead load if the deck is uncoated. The types of mesh used in the schedule are the most commonly used in North America. The concrete is req. min. 3,500 psi normal-weight or light-weight concrete. The mesh is draped over the top chord of the joist, which acts as a chair, down to the top of the decking. It appropriately resists the slab's negative and positive moments.

Εἰς τὴν ἰαίρυάᾱ ἔαΕψςῆς ἰς ῆῆῆῆ ἔαίῆᾱ ὀψ! ᾶᾶ ῆῆῆῆ! | Εᾶᾶῆῆᾶ

<b>Standard Design - Residential - UL Fire Rating</b>	BXUV.G531
<b>Deck Type and Slab Thickness</b>	3 ½" Slab Including 1 5/16" UFX Steel Form Deck
<b>Vertical Leg of Top Joist Chord</b>	2 ½"
<b>Normal Weight</b>	145 lbs. / CF
<b>Slab Weight with Joist and Deck</b>	40 lbs.

<b>Maximum Unshored Deck Span During Construction (ft)</b>	<b>Gauge</b>
Up to 5'-3"	24
5'-3" to 6'-0"	22
6'-0" to 7'-0"	20

Αῆῆ ἔῆᾶί ᾶᾶᾶ ἔῆῆῆῆᾶίῆ ὀψ! Εᾶῆ ᾶᾶῆᾶᾶᾶᾶᾶ

Επίπεδο: Ομογενής Εμβαλλόμενη Αρμатура με Έπιπλο Έπιπέδο Σκυμμένου

<b>Fy =</b>	60 ksi
<b>Total Dead Load =</b>	65 psf
<b>NW Concrete</b>	145 lb/ft <sup>3</sup>

Slabs with 1/4" Uncoated Deck <sup>a</sup>				Maximum Live Load (psf)										
				Deck Span between Joists or Other Supports (ft)										
Slab Depth (in)	Reinforcement	As (in <sup>2</sup> /ft)	ΦM <sub>n</sub> (k-in/ft)	3.5	3.75	4	4.33	4.5	4.75	5	5.25	5.5	5.75	6
3.5	6"x6" W2.1/W2.1	0.042	4.58	166	138	115	91	81	68	56	47	38	31	24
	6"x6" W2.9/W2.9	0.058	6.28	245	207	176	143	129	111	95	82	70	60	51
	6"x6" W4.0/W4.0	0.08	8.57	352	300	258	213	194	169	148	129	114	100	88
	Double 6"x6" W2.1/W2.1	0.084	8.98	371	317	273	226	205	179	157	138	121	107	94

α) Η επιπέδωση είναι ομογενής με αρμатура έπιπέδου σκυμμένου. Η επιπέδωση είναι ομογενής με αρμатура έπιπέδου σκυμμένου. Η επιπέδωση είναι ομογενής με αρμатура έπιπέδου σκυμμένου.

<b>Fy =</b>	60 ksi
<b>Superimposed Dead Load =</b>	25 psf <sup>b</sup>
<b>NW Concrete</b>	145 lb/ft <sup>3</sup>

Slabs with 1/4" Coated or Galv. Deck <sup>c</sup>				Maximum Live Load (psf)										
				Deck Span between Joists or Other Supports (ft)										
Slab Depth (in)	Reinforcement	As (in <sup>2</sup> /ft)	ΦM <sub>n</sub> (k-in/ft)	3.5	3.75	4	4.33	4.5	4.75	5	5.25	5.5	5.75	6
3.5	6"x6" W1.4/W1.4	0.028	3.08	125	107	91	75	68	59	52	45	40	35	30
	6"x6" W2.1/W2.1	0.042	4.58	196	168	145	121	111	98	86	77	68	61	54
	6"x6" W2.9/W2.9	0.058	6.28	275	237	206	173	159	141	125	112	100	90	81
	6"x6" W4.0/W4.0	0.08	8.57	382	330	288	243	224	199	178	159	144	130	118
	Double 6"x6" W2.1/W2.1	0.084	8.98	401	347	303	256	235	209	187	168	151	137	124

β) Η επιπέδωση είναι ομογενής με αρμатура έπιπέδου σκυμμένου. Η επιπέδωση είναι ομογενής με αρμатура έπιπέδου σκυμμένου. Η επιπέδωση είναι ομογενής με αρμатура έπιπέδου σκυμμένου.



# COMPOSITE ACTION OF THE VESCOM TOP CHORD

## 4.1 Composite Design

Composite steel construction combines steel and concrete to leverage the strengths of both materials to meet design parameters. It's widely used in modern buildings, bridges, and infrastructure projects due to its reduced weight, increased efficiency, increased strength, and cost-effectiveness.

The steel and concrete elements behave compositely when they are restrained from moving relative to each other. This is accomplished through shear connectors that restrain the relative movements during both the serviceability range and the strength limits of the designs; they must also exhibit ductility during overload conditions to ensure code approved safe designs. Vescom utilizes “dimples” which are mechanically fabricated embossments on the embedded top chord of the joists to ensure this composite behavior.

## 4.2 Composite Design in the Steel Joist Industry

Elevated slabs with relatively thin concrete decks and supporting bar joists are an ideal application of composite concrete and steel construction. For at least the past 75 years, the joist industry has been aiming to combine bar joists and the concrete deck with a composite connection efficiently and cost-effectively. Vescom solved this composite connection issue with a unique mechanical connection, using dimples on the enclosed vertical angle legs of the top chord and the welded wire mesh over the top chord to form a unique composite connection. The Vescom integrally dimpled top chord has been shown in testing and through 40 years, with millions of square feet of usage to ensure the composite behavior of the open web joists and the concrete deck.

## 4.3 Vescom Composite Advantages

The combination of the concrete with the Vescom joists increases the effective depth of the joist, increasing its moment of inertia and, in turn, its flexural strength, stiffness, and capability. The effect allows shallower sections for supporting floor loads which in turn decrease the floor to floor heights.

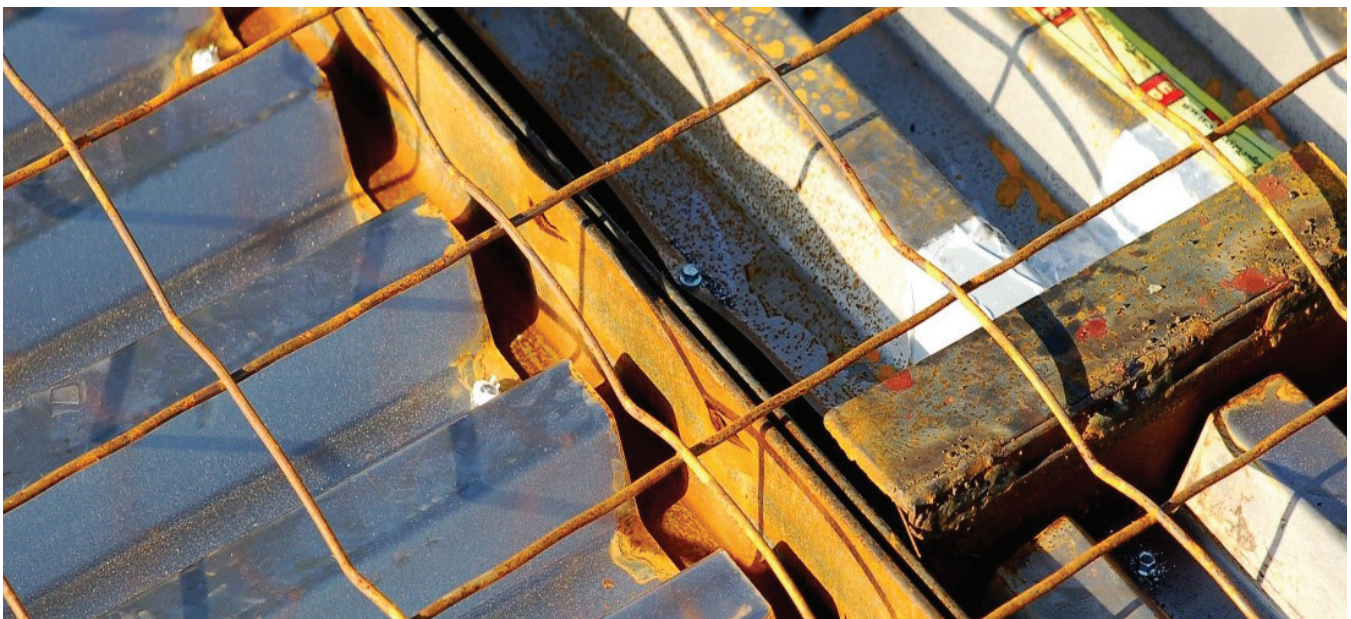

# VESCOM FLOOR SYSTEM DESIGN

## 5.1 Vescom Design

All joists are custom-designed to fit their unique location and applicable design load requirements. All Vescom joists and girders are designed using LRFD (Load Resistance Factor Design) methods and a finite element model for both the composite construction phase and the composite final use stage.

Vescom meets all IBC requirements of both uniformly distributed loads and minimum concentrated live loads. Vescom will design special joists and trusses to support point load, multiple uniform loads, midspan connections, and other special requirements when specified by the design professional.

## 5.2 Vescom Design Methods

Each joist is specified with a unique label and number to identify it on the plans; this label is unique to each project and may be repeated for identical joists. The joists are spaced with typical spacing but with variations in that spacing throughout based on the unique layout of the building. Joist depth and typical spacing are identified at the beginning of a design project by the architect and/or engineer, depending on the required span lengths and the desired clear ceiling heights. Several parameters, including zoning and height restrictions, influence the floor-to-floor heights, which in turn affect the joist depth and ceiling height.

## 5.3 Vescom Joist Depth

Joists have an optimum efficient depth in relation to their span for a typical uniformly loaded floor member. For this typical case, the most efficient depth of a Vescom Composite Joist at a given span is given by the following graphic:

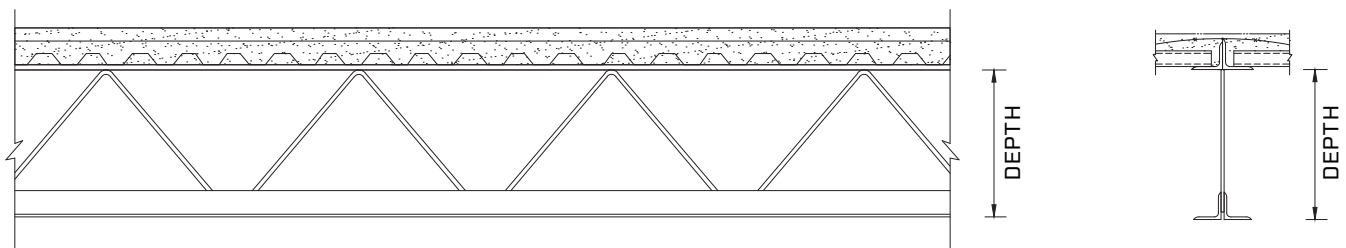

L 0 1 2 3 4 5 6 7 8 9 10 11 12 13 14 15 16 17 18 19 20 21 22 23 24 25 26 27 28 29 30 31 32 33 34 35 36 37 38 39 40 41 42 43 44 45 46 47 48 49 50 51 52 53 54 55 56 57 58 59 60 61 62 63 64 65 66 67 68 69 70 71 72 73 74 75 76 77 78 79 80 81 82 83 84 85 86 87 88 89 90 91 92 93 94 95 96 97 98 99 100

For any given joist depth, the Vescom Composite Joist's span can vary up to the maximum span limit depicted in the Depth vs Span graph. Any depth-span pairs beyond the maximum span limit can be designed as Long-span Joists.

## VESCOM JOIST: DEPTH VS. SPAN

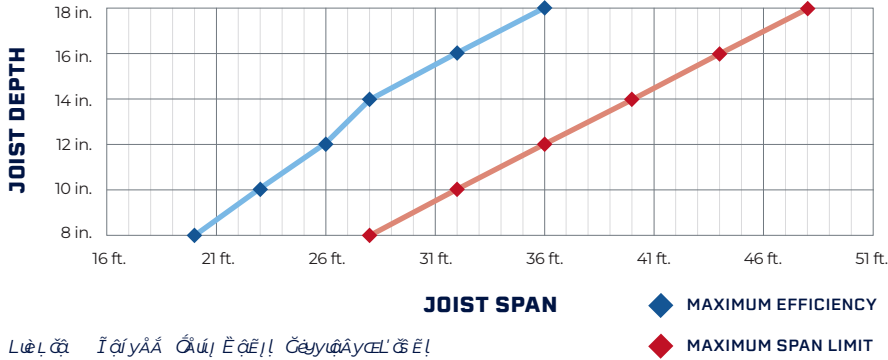

Many parameters, including zoning and height restrictions, determine the floor-to-floor heights, which determine the joist depth and ceiling height. Vescom will endeavor to design the joist to fit the architectural needs of the building concept.

The following guide shows customary joist depth choices for residential floor construction, including an attached ceiling. (UL Fire Rating BXUV G531).

Depth of Joist	Joist Span	Depth of Construction	Floor to Floor Height for 9'-0" Ceilings
8V	20'	13"	10'-1"
10V	25'	15"	10'-3"
12V	30'	17"	10'-5"
14V	35'	19"	10'-7"
16V	40'	21"	10'-9"
18V	45'	23"	10'-11"
20V	50'	25"	11'-1"

## 5.4 Vescom Floor Diaphragm

Vescom develops the shear capacity of the composite behavior without relying on the nonlinear skin friction. We implement deformations of the top chord that present a physical impediment to the shear movement and develop a predictable ductile behavior. Based on the design and testing of the joists to date for design, with the minimum 6x6-2.1/2.1 WWM, we used a minimum diagram shear capacity of 3k/ft.

Utilizing ACI 318-2019 eq (12.5.3.3) with 3500 psi NW concrete and WWM 6x6-w2.1w2.1 yields:

$$V_n = A_{cv} (2\lambda \sqrt{F'_c} + \rho_t F_y)$$

Where:

$A_{cv}$  = dept of concrete above deck (3.5"-1 5/16") \* 12 inch/ft

$\lambda$  = 1.0

$F'_c$  = 3,500 psi

$A_s$  = 0.04ln2/ft /  $A_{cv}$

$F_y$  = 70,000 psi

This yields  $V_n$  of 5.9 Kips/ft perpendicular to the joists.

The Design Shear Stiffness,  $G'$  is a material property that is not directly specified within the ACI code with respect to diaphragm. The Shear Stiffness  $G'$  should conservatively be designed as if the slab was a uniform thickness, without the inclusion of the slab stiffening due to the composite joists, metal decks, bearing walls, integral diaphragm boundary elements, etc. Due to this, it can be solely based on the concrete slab with the assumption that the concrete is isotropic using the relationship from hooks law which states:

$$E = 2G(1+\nu)$$

Where:

$E$  = modulus of elasticity of the concrete per ACI Eq 19.2.2.1.b ( $E_c = 57000(f'_c)^{1.5}$ )

$\nu$  = poison's ratio for concrete = varies from 0.1 for high strength concrete to 0.2 for low strength concrete.

As a basis of design, we have frequently analytically designed the slab using a 2-dimensional plane strain element with the lateral loads applied at the perimeter for wind loads and the center of gravity for the earthquake loads being resisted by the shear walls. This allowed the loads to be distributed based on the relative stiffness of the slab, with openings, and the shear resting walls or frames. This analysis, when then viewed as principal stresses, allowed the slab to be weighed directly against the shear capacity of the slab. In the few rare cases when, due to the geometrical shear concentrations of the slab the diaphragm, loads exceed the natural shear capacity, additional mesh or reinforcement can be required.

## 5.5 Vescom Joist Spacing

The joists are laid out with a typical spacing per the following parameters.

### 5.5.1 THE UL FIRE RATINGS MUST BE CONFIRMED IF A SHEETROCK CEILING IS ATTACHED.

For the UL Fire Rating, BXUV G531 (Residential with an attached ceiling), the joists have a typical span between joists of 4'-4". It can vary depending on architectural and mechanical restrictions. The maximum dimensions are 6'-0" on center. If the dimensions are greater than 4'-4", please inquire about the UL rating for qualifications.

### 5.5.2 LENGTH, LOAD, ECONOMY, AND LAYOUT WILL DICTATE THE OPTIMUM SPACING BETWEEN JOISTS.

As a general guide, the spacing of Vescom joists for residential buildings is between 4'-0" and 5'-0". In institutional and commercial buildings, the span between joists is typically spaced 5'-0" to 6'-0" apart.

The spacing between joists can vary in isolated locations to adjust for MEP (mechanical, electrical, plumbing) penetrations in slabs, structural connections, etc.

## 5.6 Vescom Joist Designation

The drawings designate each Vescom member with depth, type of joist, design load requirement, conceptual length, and end configurations. These parameters and the tributary width design the typical uniform load joist.

The designation is represented in the example below:

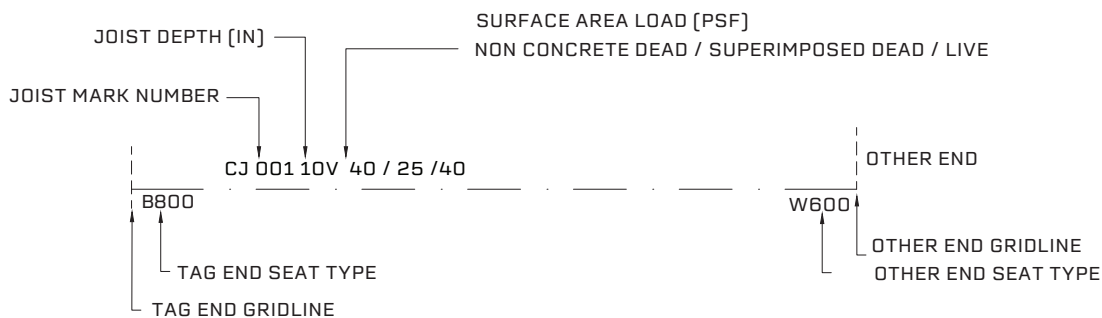

ⓁⓊⓁⓁ̄ Ḳ̄ḳ̄ḳ̄ḳ̄ Ḳ̄ḳ̄ḳ̄ḳ̄ Ḳ̄ḳ̄ḳ̄ḳ̄ Ḳ̄ḳ̄ḳ̄ḳ̄ Ḳ̄ḳ̄ḳ̄ḳ̄ Ḳ̄ḳ̄ḳ̄ḳ̄

The **TAG END** is the end of the joist with the label or tag; the opposite is the **OTHER END**. **CJ-001** is the Joist Label, a unique number assigned to each joist; identical joists can be given the same label.

**10** is the joist's depth in inches, as measured from the top chord's underside to the bottom chord's underside; in this case, it is 10 inches. Typical joist depths are 8 in., 10 in., 12 in., 14 in., 16 in., 18 in., etc.

The **V** indicates that the member is a Vescom Composite Joist.

**40/25/40** are the Surface Area Loads on the slab the joist is supporting, divided into non-composite dead psf, superimposed dead psf, and live psf in that order.

The **SUPPORT LABEL** identifies the bearing condition on each end of the joist; it defines the top and bottom chord extensions, the distance to the first web, and the distance to the gridline. See Bearing Support Catalog.

The **SPAN BETWEEN GRIDLINES** is the distance between referenced gridlines in feet and inches. The gridlines are usually in the center of supports (beams, trusses, walls, and columns) except for walls which may be measured to the face, especially those that are 6" or larger.

The **TRIBUTARY WIDTH**, not visibly labeled on the joist, is half the distance to the neighboring joist or other member on each side, measured in feet. This value is typically 4'-4"; if a series of joists with all other properties but the tributary width are the same, the tributary width measuring the largest can be given to the series of joists such that all those joists can have the same label number.

## 5.7 Vescom Joist Deflection

Joists can be ordered with a maximum composite slab deflection requirement of  $L/360$  or  $L/480$ , and special deflection requirements can be achieved.

## 5.8 Vescom Joist Camber

The Vescom joists' camber is set to approximate the calculated dead load deflection at a 2400 ft constant radius, equal to the approximate non-composite deflection.

If required by circumstance, a custom camber can be requested and implemented as necessary.

## 5.9 Vescom Joist Vibration

The length, depth, and composite moment of Inertia will determine vibration. The design team should evaluate these requirements and adjust the design accordingly.

## 5.10 Vescom Special Joists (SCJ or CJ\*)

Special conditions may require joists that do not have the typical uniform loading or have additional special steel components or connections. These special joists are indicated on the design document with their special designation label, either SCJ-## or CJ\*-##.

Additional information for a special joist design is required and may include any and all of the following applicable conditions: additional special design loads with their locations, special connection locations and details, special installation instructions, etc.





## 6.5 Vescom Bearing on Insulated Concrete Forms

The Vescom joist needs to bear at least 4" from the face of the ICF into the concrete core of the concrete wall. If the joists and slab are to be cast integrally with the ICF wall it must be supported during the concrete installation process, the design of which is the responsibility of the installer or design engineer.

## 6.6 Vescom Cantilever and Balcony Applications

The Vescom Joist System can be engineered to accommodate cantilevered and balcony structures. While it remains the responsibility of the Engineer of Record (EOR) to ensure that the final design complies with all applicable project requirements, codes, and load criteria, CSC's engineering and technical team will provide design assistance and coordination support as needed to help achieve the desired structural outcomes.

**REFER TO SECTION 12 OF THE TYPICAL DETAILS FOR BEARING EXAMPLES.**



# VESCOM UL FIRE RATINGS

## 7.1 Vescom Fire-Rated Assemblies

Through testing and evaluation, Vescom has multiple Underwriter Laboratory-approved fire-rated assemblies, including gypsum board membrane ceilings, attached and suspended, acoustic ceiling panels, and direct-applied fireproofing. These ratings are determined by subjecting an assembly to a standard fire exposure as defined in ASTM E119.

The Vescom UL floor assemblies are comprehensive and inclusive, but we recognize the variability of design, products, and practice. Any variation requested from the fire ratings will be brought to UL for review and consideration.

Type of Assembly	UL Fire Ratings
Acoustic Ceiling	BXUV.G203, BXUV.G211, BXUV.G222, BXUV.G243, BXUV.G229
Gypsum Ceiling	BXUV.G525, BXUV.G530, BXUV.G531*
Direct Applied Fire Resistive Material	BXUV.G701, BXUV.G703, BXUV.G705, BXUV.G707, BXUV.G708, BXUV.G714, BXUV.G717, BXUV.G801, BXUV.G805, BXUV.G806, BXUV.G808, BXUV.D780

ᐸᓂ ᓂᓄᓂ ᐃᓕᓂᓂᓂᓂ ᐃᓂᓂᓂᓂᓂ ᐃᓂᓂᓂᓂᓂ

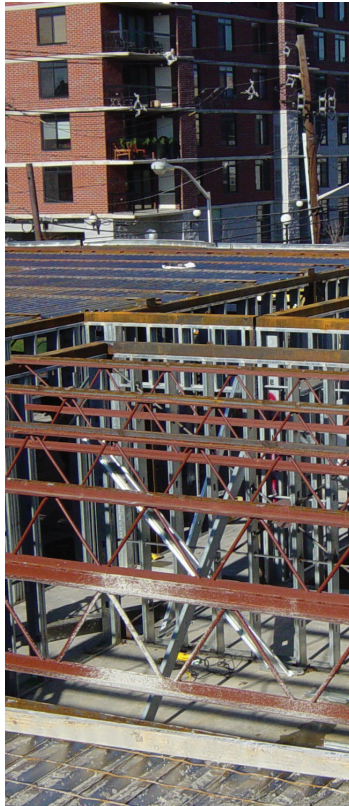

## 7.2 Vescom Fire Rating for Multi-Story Residential

\*BXUV.G531 is the premier Fire Rating for residential and related uses, such as hotels, senior independent and assisted living, nursing homes, hospitals, and dormitories. The assembly has a ceiling that can be attached quickly and cost-effectively. It also allows hung ceilings. It has multiple allowances for unprotected openings (Openings in ceilings that don't require fire dampers) for supply, return, and exhaust air, plus recessed lights and other ceiling penetrations.

The concrete requirement is 3500 PSI normal-weight concrete. It is 2 3/16" of concrete on a 1 5/16" metal decking for 3 1/2". Over the years, many projects have been built with thicker or thinner slabs. Some used lightweight concrete. Many engineers want to use 4000 PSI concrete. The ceiling requires one layer of 1/2" or 5/8" Type C gypsum board. To attach the one layer of sheetrock, 7/8" 25-gauge hat channels are connected to the bottom chord of the joist 2'-0" on center.

8" joists and deeper can be used with this rating while allowing for unprotected openings as specified in the rating. 6" joists are permitted, but do not qualify for the liberal mechanical openings allowed with deeper joists.

The welded wire mesh size is 6 X 6 W2.0/W2.0 or heavier. It is determined by the structural requirement of the span and the load. The standard parameter of the residential slab construction, a 40-pound live load, spans 52" between joists and requires the W2.0/W2.0 WWM. When the parameters change, a heavier mesh may be necessary. When it is in just one part of the project, we double up the mesh, which is sufficient.

The usual spans between the joists are 52". This is modified in multiple cases due to plumbing, mechanical, electrical, or architectural conflicts. The rating allows 6'0" spacing under the limitation that three (3) adjacent spans will not exceed 14 feet. The need for the 6-foot spacing usually occurs with back-to-back bathrooms or the need for a mechanical unit between joists.

The decking used for this rating is a 1 5/16" galvanized 24-gauge decking. Another size of decking is sometimes used for a special project requirement. Since concrete acts as a heat sink in the case of a fire, the volume of concrete per square foot must equal or exceed the typical condition.

Unprotected duct openings are allowed if they are a maximum of 20 square inches and not within 12" of a joist. One unprotected opening is permitted for every 100 square feet of ceiling area. If an apartment is 1200 square feet, 12 unprotected openings are allowed. These 100 sq. ft. areas are not 10' X 10' but can mean 12 openings where these are not clustered or concentrated in one apartment area.

Equivalent to unprotected duct openings is "plenum box outlets," larger than 20 square inches, but their construction allows them to be unprotected. Various ceiling penetrations are allowed, equivalent to the 20-square-inch opening, including 6" and 8" rounds, 10" X 8" rectangular, 10" X 10", 14" X 14", and openings for lights, exhaust ducts, etc. The construction of each opening is spelled out in the UL Rating.

Various flexible air ducts with equivalent ceiling penetrations are allowed. This allows flexible exhaust air ducts for bathrooms and kitchens to travel through the joists to the exterior wall. Venting through the exterior wall eliminates the vertical exhaust duct to the roof, which is traditionally used. It also eliminates the floor-to-floor sound transfer that is so disturbing to residents.

Hanging the ceiling and various hung ceiling assemblies are also allowed. This gives contractors flexibility when lower ceilings are required or if there are other reasons to hang the ceiling rather than attach it.

# VESCOM SOUND RATINGS

## 8.1 Vescom STC, IIC, and HIIC

STC, IIC, and HIIC are numerical ratings that measure how well a building material or assembly reduces the transmission of sound from one place to another. Sound transmission requirements for buildings are typically governed by building codes and standards that ensure proper acoustic performance. Here are some key considerations:

**SOUND TRANSMISSION CLASS (STC):** This measures how well a building material or assembly reduces airborne sound. Higher STC ratings indicate better sound insulation. For example, common interior walls between dwelling units must meet a minimum STC rating of 50 in lab tests or 45 in field tests.

**IMPACT INSULATION CLASS (IIC):** This measures how well a floor assembly reduces impact noise, such as footsteps or dropped objects. Like STC, a higher IIC rating means better sound insulation. The minimum ICC rating is 50 in lab tests or 45 in field tests.

**HIGH FREQUENCY IMPACT SOUND TEST (HIIC):** The high frequency impact sound insulation of an assembly is determined by the characteristics of the floor topping. This is typically independent of other details of the assembly. Common sources of high frequency impact sound include the impact of hard-heeled shoes, dragging furniture, etc. The higher the value the greater isolation of these sounds that are achieved meaning that the sound level in the receiving space is lower as the rating increased.

## 8.2 Vescom Sound Testing

IIC, STC, and HIIC are computed by ASTM designations E492, E989, E90, and E413. Vescom has been tested at the Intertek laboratories with typical floor finishes and underlayment used in residential and commercial building construction. HIIC is a new designation originating due to the industry's need to access separately these high frequencies due to significance in residential noise issues. The following schedule represents sample results of those tests.

Table 8.1: Sample Sound Test Results

Flooring Material/Thickness	Underlayment	STC	IIC	HIIC	Residential Apartment Location
Bare	None	56	29	29	N/A
2 mm Vinyl	1.4 mm Matting	55	58	63	Kitchen
7 mm Vinyl WPC w/ Pad Attached	Attached to Finish	55	57	65	Living Room/Bedroom/Kitchen
3/8" Engineered Wood	5 mm Rubber Mat	56	57	63	Living Room/Bedroom/Kitchen
3/4" Hardwood	5 mm Rubber Mat	55*	54*	59*	Living Room/Bedroom
Ceramic Tile	5 mm Rubber Mat	55*	53*	57*	Bathroom/Kitchen
25 Oz. Carpet	5 lb. Rebond	55	85	86	Living Room/Bedroom

\* Field Test Results

We can derive from our testing results for many other floor treatments used with a Vescom floor assembly. Vescom's sound consultant is also available to consult. Please check with your local CSC Representative for more information.

# HVAC DUCT PENETRATIONS

## 9.1 Vescom's Open Web Construction

Open web joists allow the HVAC, plumbing, electrical, and sprinkler to share the plenum space with the structure, in this case with the Vescom joists. By the nature of the Vescom joists this space is larger since the top chord goes into the slab. Vescom's truss girders are also open web and allow penetration without special openings. The combination of the joists and the trusses allows two-way mechanical circulation.

## 9.2 Special Vierendeel Openings in Vescom Trusses

Where openings in the Vescom truss members are not large enough for a duct to pass through, special openings can be constructed to accommodate them. These are done by reinforcing the surrounding steel components. These openings are easier and more possible, further from the end of the joist. They cannot be located adjacent to the seat. The structural drawings must clearly designate the location and size of the opening required.

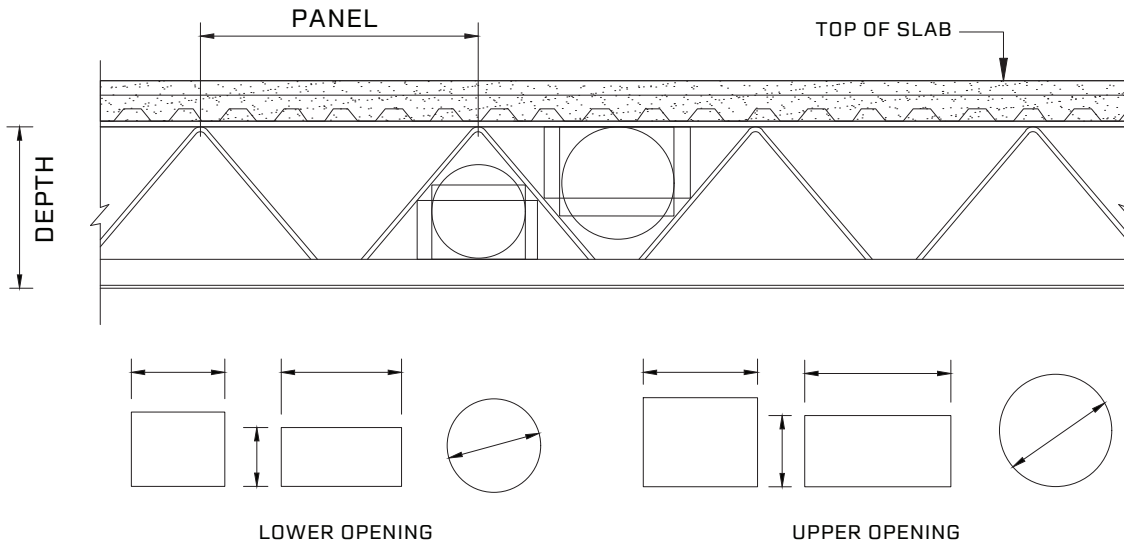

Lower opening: Için yavaş çukurluğu, üst çukurluğu ve açılımların açıklığı

## 9.3 Duct Penetrations Without Special Openings

Sizes of ducts accommodated through a typical Vescom joist without the need for a special Vierendeel opening vary based on the depth of the joist, as shown in the table.

Joist Depth	Upper Opening			Lower Opening		
	Circle Dia.	Square	Rectangle	Circle Dia.	Square	Rectangle
8 in.	4"	3"	5"x3"	5"	5"	10"x4"
10 in.	6"	4.5"	7"x4"	7"	6"	12"x4"
12 in.	7"	5.5"	9.5"x4"	9"	7.5"	10"x6"
14 in.	8.5"	6.5"	12"x4"	10"	8"	12"x6"
16 in.	9.5"	7.5"	13"x4"	11"	8.5"	13"x6"
18 in.	10.5"	8.5"	14"x4"	12"	9.5"	14"x6"

Upper opening: Için yavaş çukurluğu, üst çukurluğu ve açılımların açıklığı

# VESCOM SYSTEM ERECTION

## 10.1 Vescom Erection Advantage

The Vescom erection process is a study of speed and simplicity. It uses fewer components and less manpower; no scaffolding or bridging, no stud to install, no special spandrel formwork required by joist seats, no temporary support members, no striping of forms or roll bars, and no piles of wood forms and debris to be removed from the site.

## 10.2 The Four (4) Step Process

1. Walls, beams, or other support members frame support bays. Locations are measured and marked. Joist bundles are placed and spread quickly. Joists are attached by welding or shot.



2. Precut decking is rapidly placed between the joists and attached by shot or puddle welding. This results in a finished and safe working platform of exceptional strength and stability.



- 3.** Welded wire mesh is placed and draped on the joist and deck without the necessity of highchairs. The top chord acts as the highchair.



- 4.** The last step is pouring concrete. A 3 ½" or 4" thick slab can be placed using a dip stick to ensure perfect uniformity of slab thickness. No removal of formwork, stacking, moving, repairing, or other work is required.



# VESCOM SPECIFICATION

## SECTION 05 22 00 | VESCOM COMPOSITE FLOOR SYSTEM

### PART 1 – GENERAL

#### 1 SECTION INCLUDES

- a. Vescom composite joists.
- b. Steel decking.
- c. Slab reinforcement.
- d. Concrete slab.
- e. Accessories.

#### 2 RELATED WORK

- a. Section 03 20 00 – Concrete Reinforcing: Slab reinforcement.
- b. Section 03 30 00 – Cast-in-Place Concrete: Concrete slab.
- c. Section 05 12 00 – Structural Steel.
- d. Section 05 31 13 – Steel Floor Decking.
- e. Section 05 31 00 – Steel Decking.

#### 3 REFERENCE STANDARDS

- a. American Concrete Institute (ACI) ([www.concrete.org](http://www.concrete.org)):
  - i. ACI 318 – Building Code Requirements for Structural Concrete and Commentary.
- b. American Institute of Steel Construction (AISC)
  - i. AISC 360 – Specifications for Structural Steel Buildings and Commentary.
- c. American Welding Society (AWS) ([www.aws.org](http://www.aws.org)):
  - i. AWS D1.1/D1.1M – Structural Welding Code - Steel.
  - ii. AWS D1.3/D1.3M – Structural Welding Code - Sheet Steel.
- d. ASTM International (ASTM) ([www.astm.org](http://www.astm.org)):
  - i. ASTM A307 – Standard Specification for Carbon Steel Bolts, Studs, and Threaded Rod 60000 PSI Tensile Strength.
  - ii. ASTM F3125/F3125M – Standard Specification for High Strength Structural Bolts and Assemblies, Steel and Alloy Steel, Heat Treated, Inch Dimensions 120 ksi and 150 ksi Minimum Tensile Strength, and Metric Dimensions 830 MPa and 1040 MPa Minimum Tensile Strength ASTM A529/A529M – Standard Specification for High-Strength Carbon-Manganese Steel of Structural Quality.
  - iii. ASTM A563/A563M – Standard Specification for Carbon and Alloy Steel Nuts.
  - iv. ASTM A572/A572M – Standard Specification for High-Strength Low-Alloy Columbium-Vanadium Structural Steel.
  - v. ASTM A653/A653M – Standard Specification for Steel Sheet, Zinc-Coated (Galvanized) or Zinc-Iron Alloy-Coated (Galvannealed) by the Hot-Dip Process.
  - vi. ASTM A992/A992M – Standard Specification for Structural Steel Shapes For Use in Building Framing.
  - vii. ASTM A1008/A1008M – Standard Specification for Steel, Sheet, Cold-Rolled, Carbon, Structural, High-Strength Low-Alloy, High-Strength Low-Alloy with Improved Formability, Required Hardness, Solution Hardened, and Bake Hardenable.
  - viii. ASTM F436/F436M – Standard Specification for Hardened Steel Washers.
- e. Society for Protective Coatings (SSPC) ([www.sspc.org](http://www.sspc.org)):
  - i. SSPC Painting Manual.
  - ii. SSPC-Paint 15.
- f. Steel Joist Institute (SJI) ([steeljoist.org](http://steeljoist.org)):
  - i. Code of Standard Practice for Composite Joists (SJI-CJ COSP-2015)
  - ii. SJI Technical Digests (TD13)
- g. Steel Deck Institute (SDI) ([www.sdi.org](http://www.sdi.org)):
  - i. SDI FDDM – Floor Deck Design Manual.
  - ii. SDI MOC3 – Manual of Construction with Steel Deck.

#### **4 PRE-INSTALLATION MEETING**

- a. Convene pre-installation meeting 1 week before start of Work of this Section.
- b. Require attendance of parties directly affecting Work of this Section, including Contractor, Architect, Engineer, and installer.
- c. Review the Following:
  - i. Materials.
  - ii. Installation/erection.
  - iii. Field quality control.
  - iv. Adjusting.
  - v. Protection.
  - vi. Coordination with other Work.

#### **5 SUBMITTALS**

- a. Comply with Division 01.
- b. Submittals for Review:
  - i. Product Data: Submit manufacturer's product data, indicating joist and decking profiles, characteristics, dimensions, structural properties, materials, and finishes.
  - ii. Joist Layout Drawings: Submit manufacturer's layout drawings, including plans, slab openings per structural drawings, elevations, sections, and details, indicating the following:
    1. Joists: Joist identification numbers, types, locations, spacings, and attachments.
    2. Decking: Decking plan, support locations, relevant details, and accessories.
    3. Calculations: Comprehensive engineering analysis of composite joists [signed and sealed by the qualified professional engineer]. Submitted after approval process prior to fabrication.

#### **6 QUALITY ASSURANCE**

- a. Manufacturer's Qualifications: Member of the Steel Joist Institute who regularly produces composite steel joists and joist girders conforming to SJI's requirements.
- b. Manufacturer's responsibilities include providing engineering services for designing joists that comply with performance requirements shown on the approved joist layout drawings.
- c. Field Welder's Qualifications: AWS D1.1/D1.1M and AWS D1.3/D1.3M.

#### **7 DELIVERY, STORAGE, AND HANDLING**

- a. Deliver, store, and handle Vescom joists, decking, and accessories as recommended in SJI Specifications and SJI TD13.
- b. Store joists and decking off ground.
- c. Protect materials from damage.
- d. Store decking in accordance with SDI MOC3, with one end elevated to provide drainage.
- e. Protect decking with vented, waterproof covering.
- f. Place decking bundles on structural steel members in accordance with SDI MOC3.
- g. Tie down loose decking bundles to prevent wind damage.

## **PART 2 – PRODUCTS**

### **1 MANUFACTURERS**

- a. Manufacturer: CSC/Vescom

### **2 DESIGN CRITERIA**

- a. Design Requirements:
  - i. Design composite floor joists under supervision of a professional engineer.
  - ii. Camber joists based on constant radius of 2400 ft.
  - iii. Maximum Allowable Live Load Deflection: Span/360

### **3 MATERIALS**

- a. Composite Joists
  - i. Steel Shapes:
    - 1. ASTM A572/A572M, 50 ksi.
    - 2. ASTM A529/A529M, 50 ksi.
    - 3. ASTM A992/A992M.
- b. Galvanized Steel Sheet:
  - i. ASTM A653/A653M Grade 40, 50, or 80 as indicated on structural drawings.
- c. Uncoated or Shop Primed Steel Sheet:
  - i. ASTM A1008/A1008M. Grade 40, 50, or 80 as indicated on structural drawings
- d. Slab Reinforcement: Specified in Section 03 20 00.
- e. Concrete Slab: Specified in Section 03 30 00.
- f. Accessories
  - i. Bolts, Nuts, and Washers: ASTM A307, ASTM A325, ASTM A563, and ASTM F436.
  - ii. Screws: ASTM C1513.
- g. Touch-Up Paint for Galvanized Surfaces: SSPC-Paint 20, Type I or II.
- h. Welding Materials: AWS D1.1/D1.1M and AWS D1.3/D1.3M; type required for materials being welded.

### **4 FABRICATION OF VESCOM JOISTS**

- a. Fabricate steel joists in accordance with manufacturer's standard practice.
- b. Top and Bottom Chord Members:
  - i. Two structural steel angles welded back-to-back top chord.
  - ii. Two structural steel equal leg angles bottom chord.
  - iii. Minimum Yield Strength: 50,000 psi.
- c. Web Members:
  - i. Round rods; crimped or un-crimped angles; rectangular bars; cold-formed angles.
  - ii. Minimum Yield Strength: 50,000 psi.
- d. Welding Materials and Methods: In accordance with SJI COSP.
- e. Primer: Apply manufacturer's standard gray primer in accordance with SSPC-Paint 15 and manufacturer's recommendations and standards. With the exception of the top chords. Top chords vertical legs shall have no more than 30% coverage of primer.

### **5 FABRICATION OF STEEL DECKING**

- a. Manufacture steel decking and accessories in accordance with SDI FDDM2.
- b. Manufacture decking as indicated on structural drawings.
  - i. Metal deck coating shall meet or exceed the drawings specifications.
  - ii. Finish: As indicated on drawings.
  - iii. Accessories: Fabricate in accordance with SDI FDM02 and manufacturer's standards.

## **PART 3 – EXECUTION**

### **1 EXAMINATION**

- a. Examine areas to receive composite floor system.
- b. Verify surfaces to support composite floor system are clean, dry, flat, plumb, level, square, stable, rigid, and capable of supporting the weight.
- c. Notify Architect of conditions that would adversely affect installation.
- d. Do not begin installation until unacceptable conditions are corrected.

### **2 INSTALLATION – GENERAL**

- a. Install composite floor system in accordance with manufacturer's instructions at locations indicated on the drawings.
- b. Install composite joists plumb, level, square, and true to line.
- c. Anchor composite floor system securely in place to supports as indicated on the drawings.

### **3 INSTALLATION OF VESCOM COMPOSITE JOISTS**

- a. Care shall be exercised to avoid damage through careless handling during unloading, storing and erecting.
- b. No construction loads shall be placed within a bay until all Vescom joists, trusses, and deck have been properly attached per project plans.
- c. During the construction period, the contractor shall provide means of adequate distribution of concentrated loads so that the carrying capacity is not exceeded.
- d. Joists must be attached per the approved drawings to support members before any decking is placed.
- e. Joists shall have a nominal bearing of 2 ½" on steel and 3 ½" when installed directly on masonry and concrete. Bearing conditions on masonry and concrete shall be in accordance with the provisions of ACI 530 and ACI 530.1.
- f. Tie joists and trusses shall be bolted or welded at the top chords only. After the concrete has been placed, and all construction loads are in place, the bottom chord members shall be welded to the columns. (Do not remove any guy wires until all top and bottom chords have been secured.)
- g. Erect steel joists and accessories in accordance with manufacturer's instructions, SJI Specifications, and as indicated on the drawings.
- h. Lift and support joists in upright position during unloading and erection.
- i. Place joists plumb, at elevations, lines, and spacings as indicated on the drawings.
- j. Complete joist attachment to supporting members before placing decking.
- k. Complete joist and decking attachments in each bay before applying construction loads.
- l. Provide minimum bearing length as indicated on the drawings.
- m. Provide for distribution of concentrated loads incurred during erection.
- n. Welding: Conform to AWS D1.1 requirements.
- o. Do not make corrections or alterations to joists without approval of manufacturer and structural engineer of record.

### **4 INSTALLATION OF STEEL DECKING**

- a. Install steel decking and accessories in accordance with manufacturer's instructions, SDI Specifications, and as indicated on the drawings.
- b. Place sheets with edges up, center the end laps over the support and nest the side lap one-half corrugation.
- c. Nominal bearing shall be 1 ½" unless otherwise shown.
- d. Place decking flat and square, without warp or deflection.
- e. Provide bearing on steel in accordance with manufacturer's instructions.

## **5 ATTACHMENT TO SUPPORTING MEMBERS**

- a. Mechanically fasten or weld decking to supporting members as indicated on the drawings.
- b. Welding: Conform to AWS D1.3/D1.3M.

## **6 CUTTING AND FITTING DECKING**

- a. Cut and fit deck units and accessories at perimeter and around projections and openings.
- b. Make cuts neat and trim.

## **7 POUR STOPS**

- a. Install pour stops where indicated on drawings, upturned to top of slab.
- b. Mechanically fasten or weld pour stops in place.

## **8 PLACEMENT OF CONCRETE SLAB**

- a. Slab Reinforcement:
  - i. Welded wire fabric shall conform to ASTM A185-72, standard specifications for welded steel wire fabric for concrete reinforcement,  $F_y = 60,000$  P.S.I. minimum.
  - ii. Welded wire fabric shall be rolled out perpendicular to the Vescom composite joists, allowing proper drape.
  - iii. Place slab reinforcement for concrete slab as indicated on the drawings.
- b. Locate slab openings not shown on the drawings a minimum of 6 inches from edge of top chord of joists.
- c. Place concrete for slab as specified in Section 03 30 00 and SDI MOC3.
- d. Maintain minimum concrete slab thicknesses as indicated on the drawings.
- e. Terminate Concrete Placement:
  - i. Above beams or girders, wherever possible.
  - ii. Parallel to joists midway between joists.
- f. Locate Joints:
  - i. Perpendicular to joists over supporting member.
  - ii. Parallel to joists midway between joists.

## **PART 4 – INSPECTION**

- a. Follow inspection requirements required by owner and Section 05 12 00.
- b. Inspect steel joists for conformance to specified requirements:
  - i. Verify placement including location, alignment, and bearing.
  - ii. Inspect seat-to-support welds.
- c. Inspect steel decking for conformance to specified requirements:
  - i. Verify decking type and gage.
  - ii. Verify decking placement and alignment.
  - iii. Inspect welds and weld pattern.
  - iv. Inspect fastener types, locations, quantities, and placement.
- d. Protection
  - i. Protect installed composite floor system from damage during construction.

**END OF SECTION**

# VESCOM JOIST AND DECK ERECTION NOTES

The installation of the Vescom floor system shall strictly follow these instructions.

## 11.1 General

- a. Care shall be exercised to avoid damage through careless handling during unloading, storing and erecting.
- b. No construction loads shall be placed within a bay until all Vescom joists, trusses, and deck have been properly attached.
- c. During the construction period, the contractor shall provide means of adequate distribution of concentrated loads so that the carrying capacity is not exceeded.

## 11.2 Vescom Composite Joists

- a. All fabrication errors must be reported immediately to Vescom. Vescom will guide correction methods.
- b. No corrections are to be made without Vescom's consent. No back charges will be honored unless this procedure is followed.
- c. All joists must be lifted in the upright position during unloading and erection. All joists shall be erected plumb and with the proper spacing.
- d. Joists must be welded (or other approved connections) to support members before placing any decking. Joist shall have a nominal bearing of 2 ½" on Steel and 3 ½" on masonry.
- e. Tie joists and trusses shall only be bolted or welded at the top chord. After the concrete has been placed, the bottom chord members shall be welded to the columns (if bolting, the bolts need to be tightened). Do not remove any guy wires until all top and bottom chords have been secured.

## 11.3 Vescom Floor Deck

- a. Deck bundles shall be placed centered on the supporting walls or girders (Never directly bear on composite joists).
- b. The deck bundles shall not exceed a maximum of 100 sheets. Care should be taken to avoid overloading the supporting elements when placing bundles of steel deck on the building.
- c. Place the sheets with the hedges up, center the end laps over the support, and nest the side lap half corrugation.
- d. Nominal bearing shall be 1 ½" unless otherwise shown. Decking shall be attached per the approved plans at each deck lap in between (24" on center maximum).
- e. Welding Washers shall be used on all deck units with a metal thickness of less than 22 gauge when welded. They shall be at least 16 gauge and have a nominal 5/8" diameter puddle weld.
- f. All field welding shall be in strict accordance with the requirements of the American Welding Society (AWS).
- g. The deck segments shall be attached by welding, screwing, or power-actuated nailer upon placement.
- h. Side laps are to be fastened at mid-span, either by welding or screwing.
- i. Loose bundles of decking must be tied down to prevent the wind from blowing the sheets.
- j. Do not use any damaged sheets. If sheets become damaged after placement, such as dents in the corrugations, remedy immediately by attaching another sheet directly over the damaged one (Extra sheets are supplied on all jobs).
- k. The steel deck shall be stored off the ground, with one end elevated to provide drainage, and protected from the elements with a ventilated waterproof covering.

## 11.4 Welded Wire Mesh

- a. Welded Wire Mesh shall conform to the ASTM A185-72 Standard Specification for Welded Steel Wire Mesh for Concrete Reinforcements,  $F_y=60,000$  P.S.I. minimum.
- b. Lapping shall be in accordance with the provisions of ACI 318.
- c. Welded Wire Mesh shall be rolled out perpendicular to the Vescom Composite joists, allowing proper drape.

## 11.5 Concrete

- a. Concrete shall not be deposited in large buckets in concentrated areas of Vescom composite joists.
- b. Slab openings must be at least 6" from the Vescom composite joists.
- c. Pours should not be terminated perpendicular to the top chord whenever possible. Pours may be broken parallel to the joist only at mid-span between the joists.



# VESCOM TYPICAL AND SPECIAL DETAILS

While all buildings present unique opportunities and requirements for specific details and conditions below are some typical and recurring special details for reference. Additional conditions and details can be produced to assist with your buildings through contact with your CSC representative.

**TYP. DETAIL AT OPNG. NEXT TO COMP. JOIST      DETAIL 3**

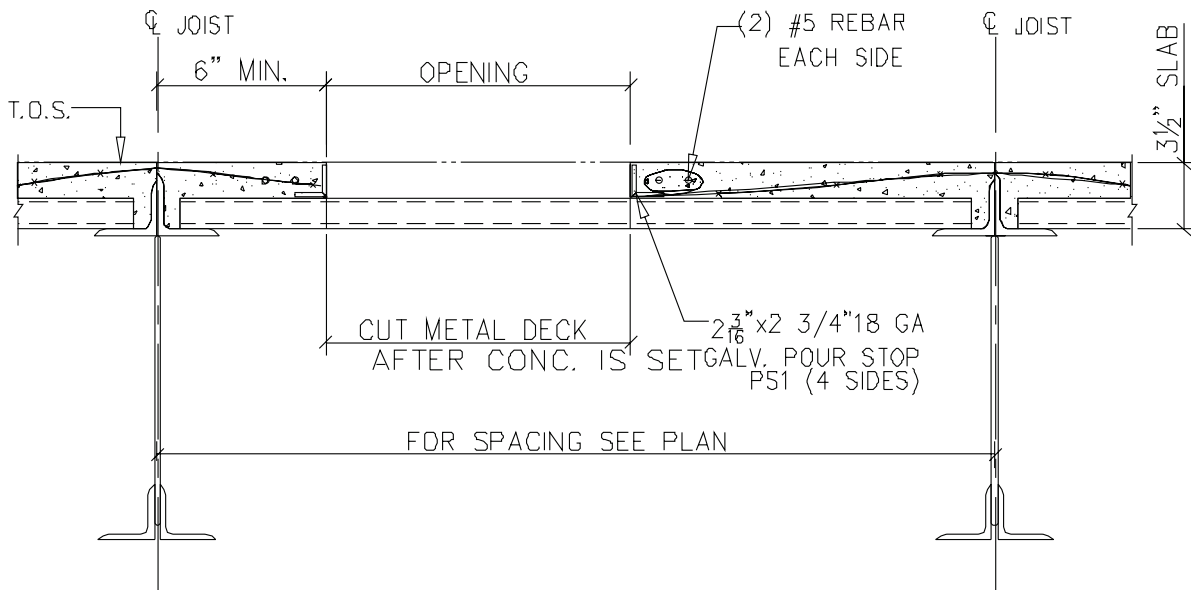

**TYP. REBAR LOCATION @ OPENINGS DETAIL 4**

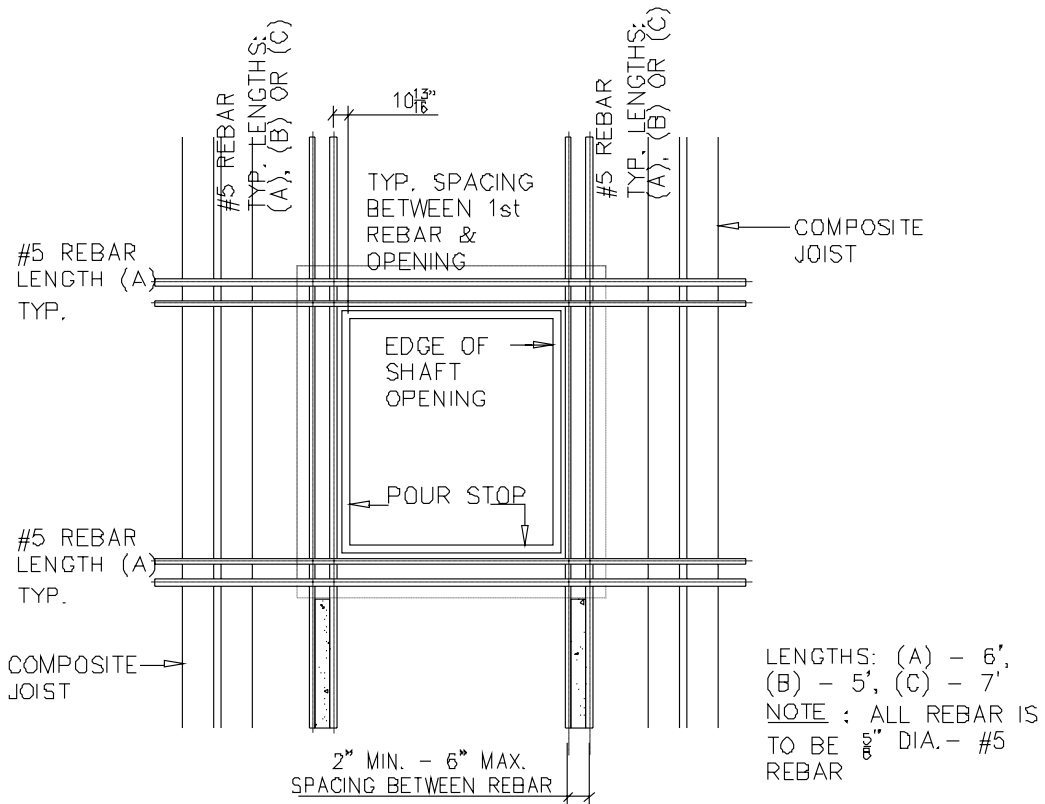

**JOIST SEAT ON CFS 6" EXTERIOR WALL DETAIL 5**

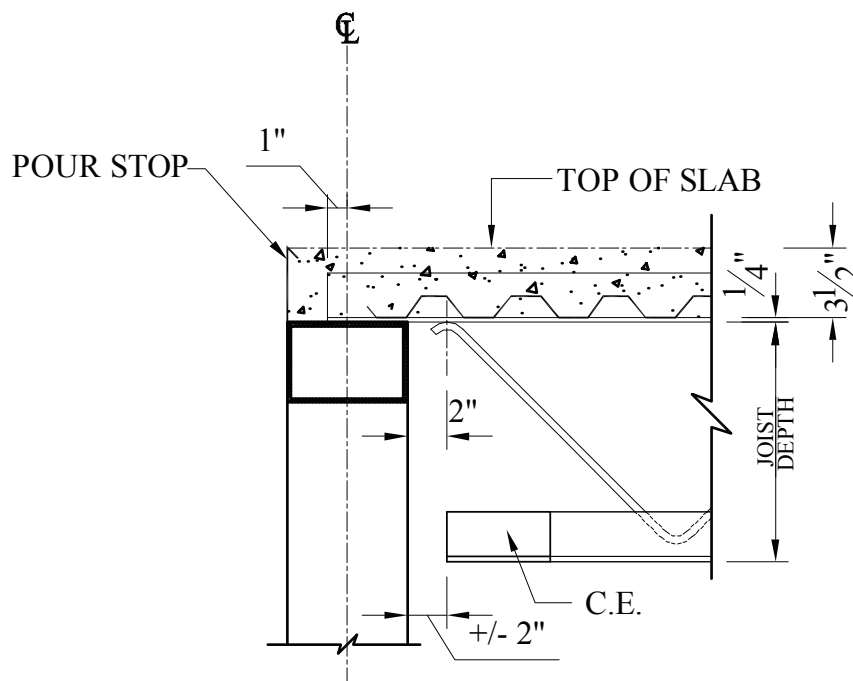

**JOIST AND MINI-JOIST SEAT ON INTERIOR CFS WALL DETAIL 6**

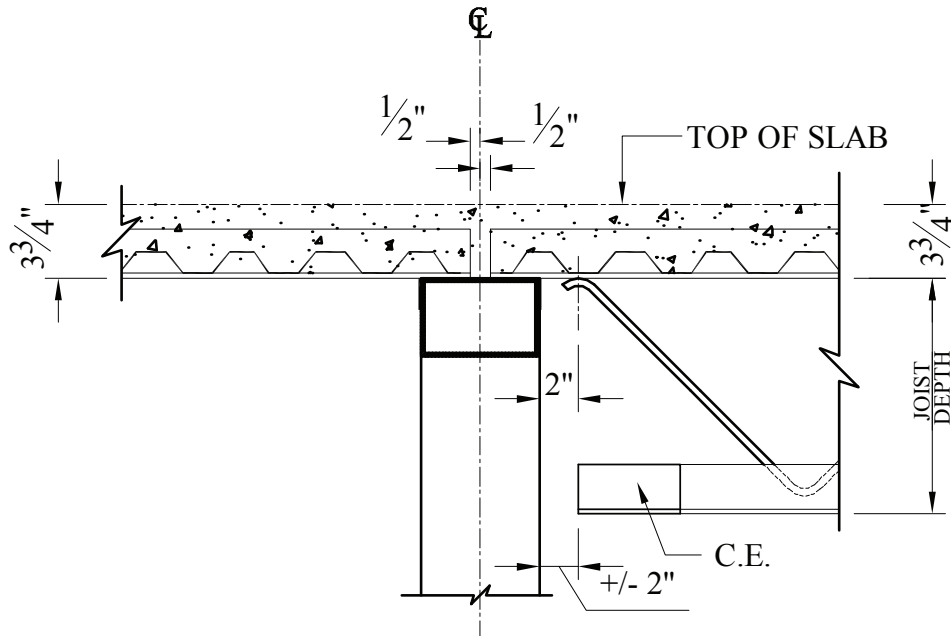

**JOIST PARALLEL TO CFS WALL DETAIL 7**

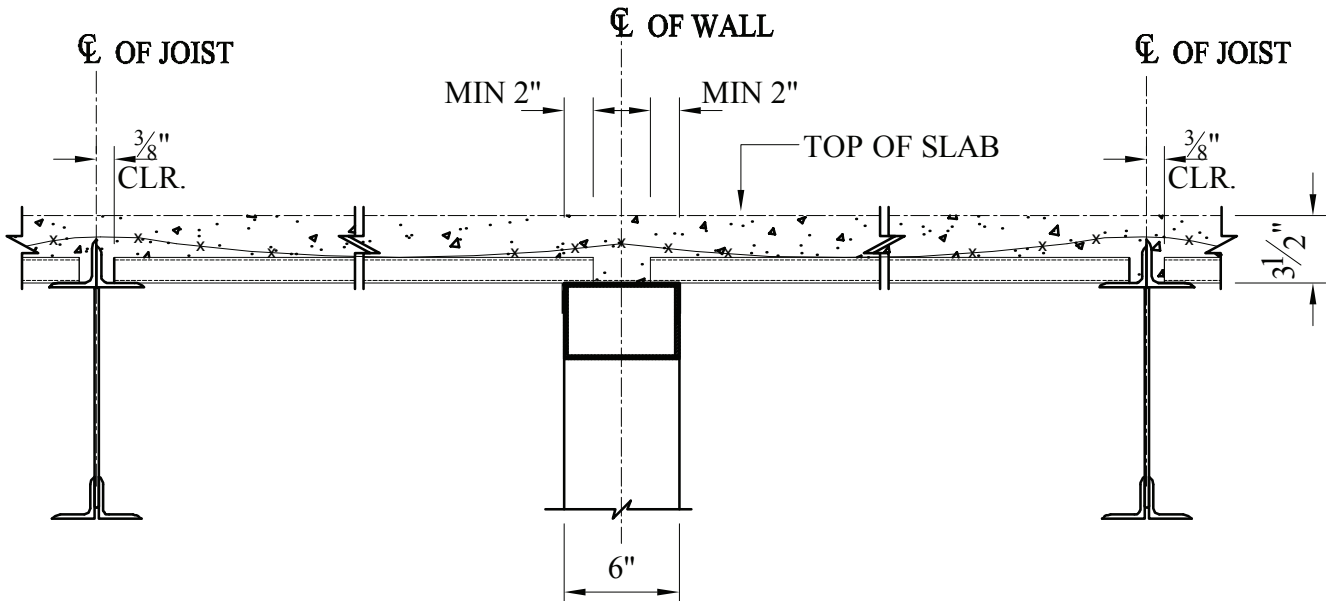

## JOIST SEAT ON 8" MASONRY EXTERIOR WALL DETAIL 8

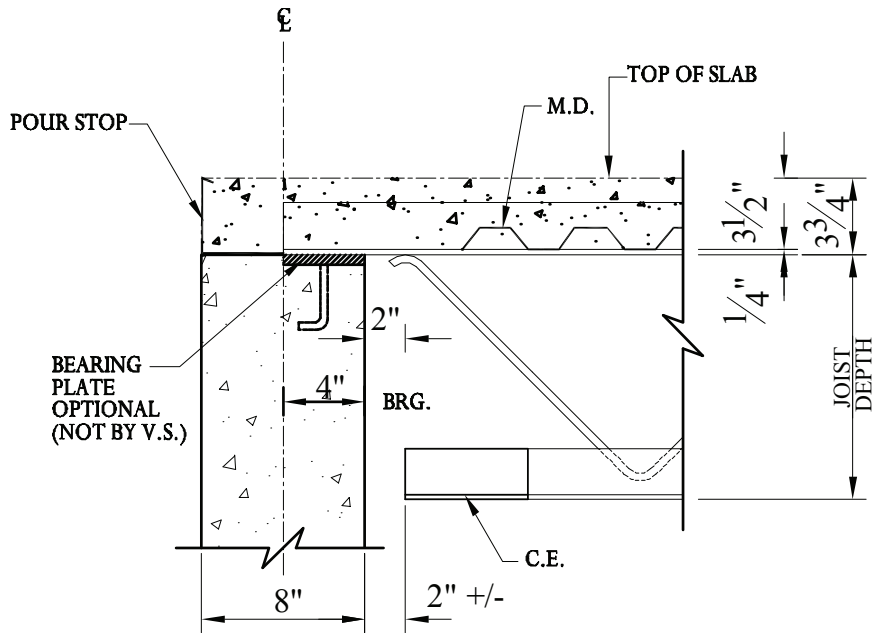

## JOIST AND MINI-JOIST SEAT ON INTERIOR 8" MASONRY WALL DETAIL 9

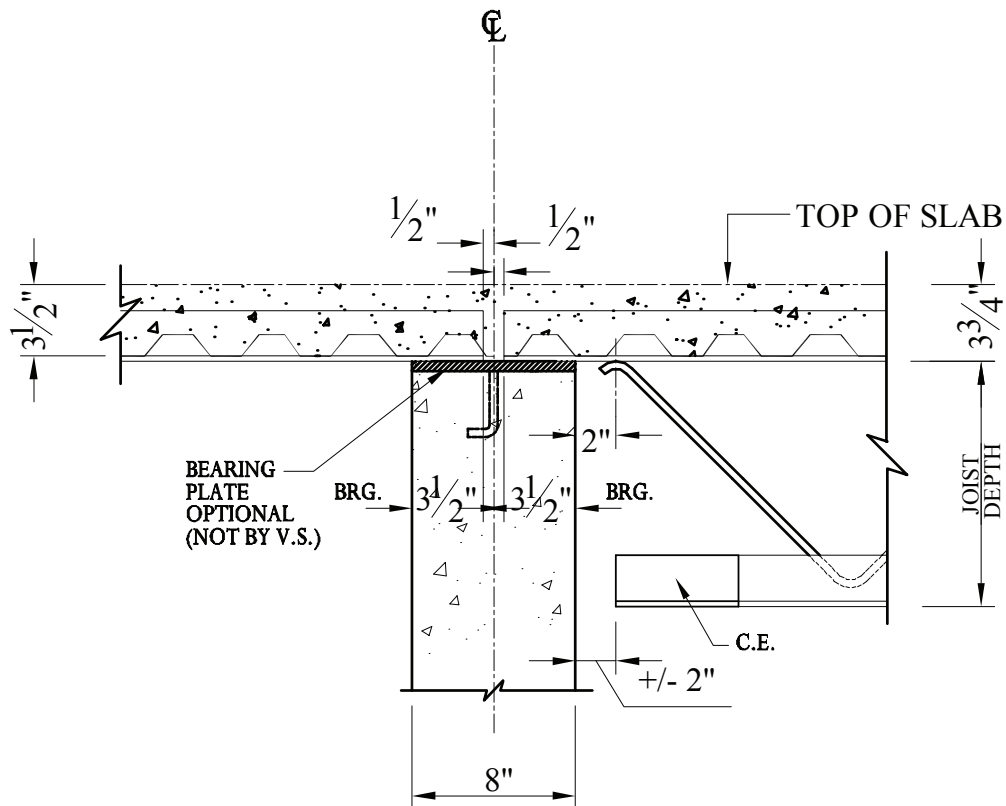

JOIST PARALLEL TO 8" MASONRY WALL DETAIL 10

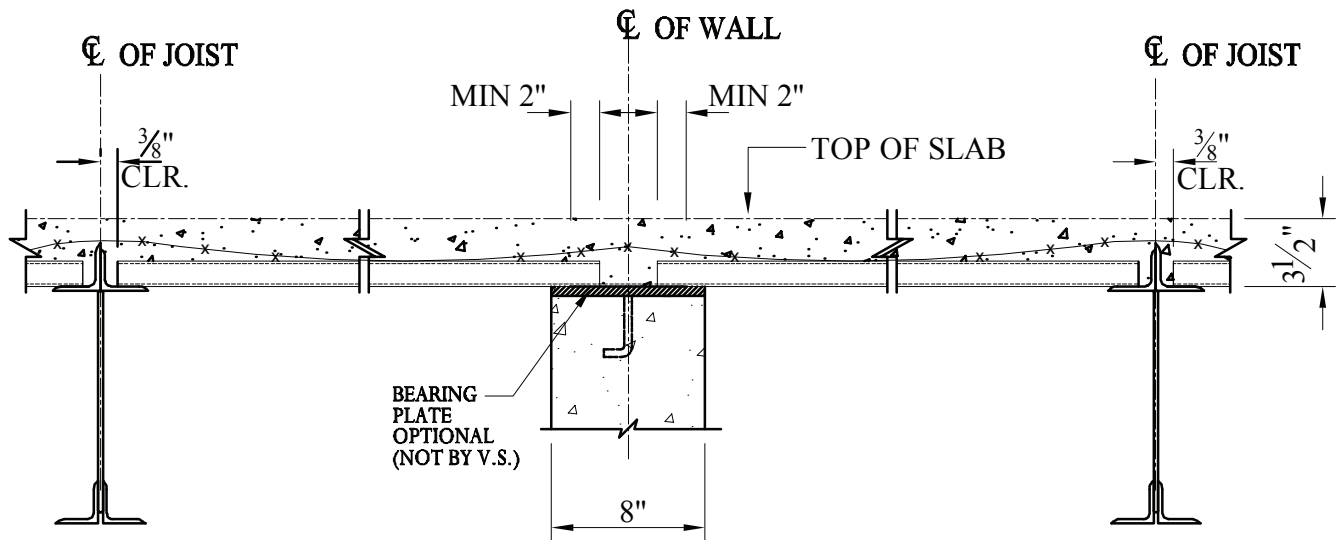

JOIST SEAT ON EXTERIOR STEEL BEAM DETAIL 14

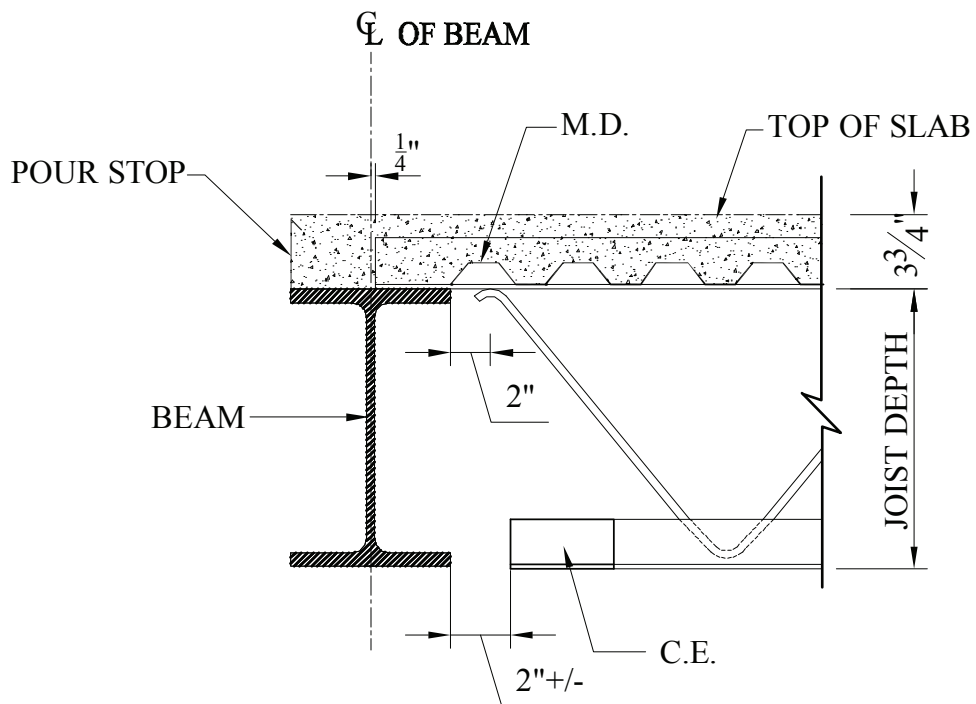

**JOIST AND MINI-JOIST SEAT ON INTERIOR STEEL BEAM DETAIL 15**

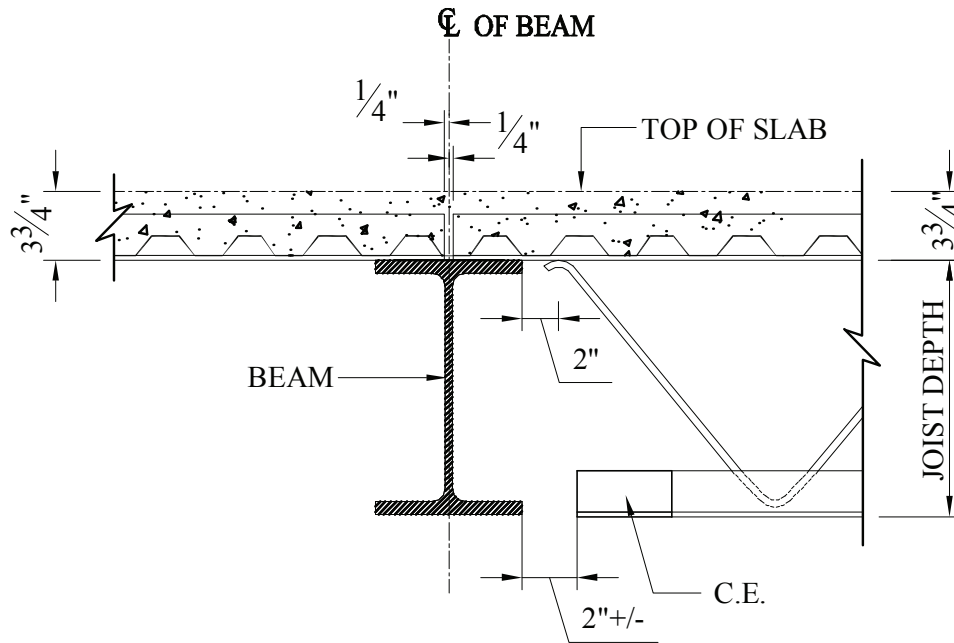

**JOIST PARALLEL TO STEEL BEAM DETAIL 16**

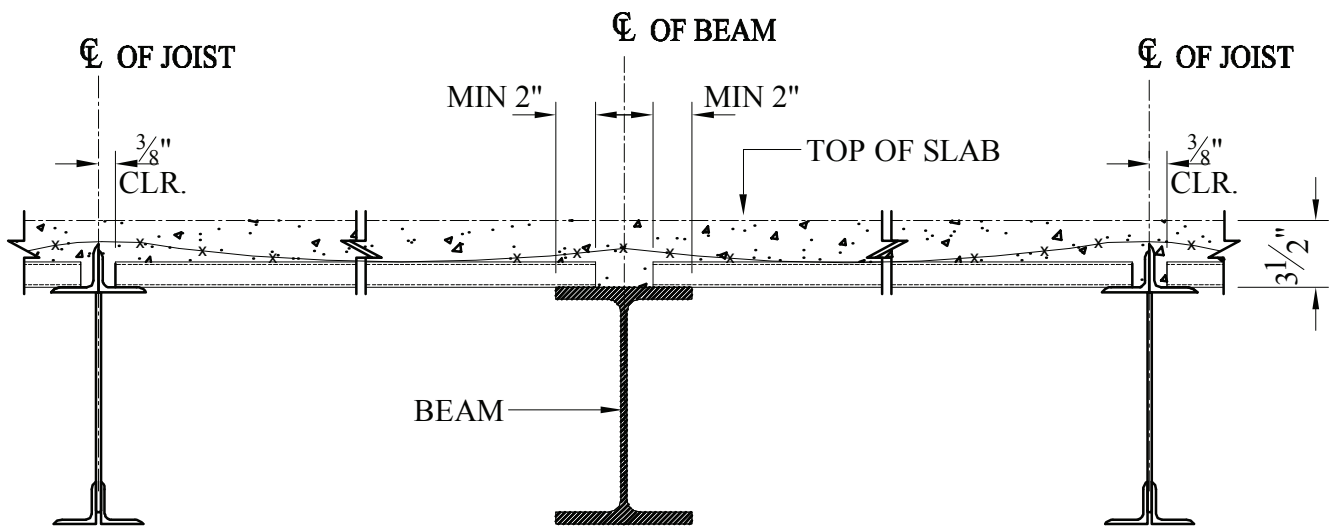

**JOIST CONNECTION TO COLUMN (FLANGE) 2 BOLTS DETAIL 17**

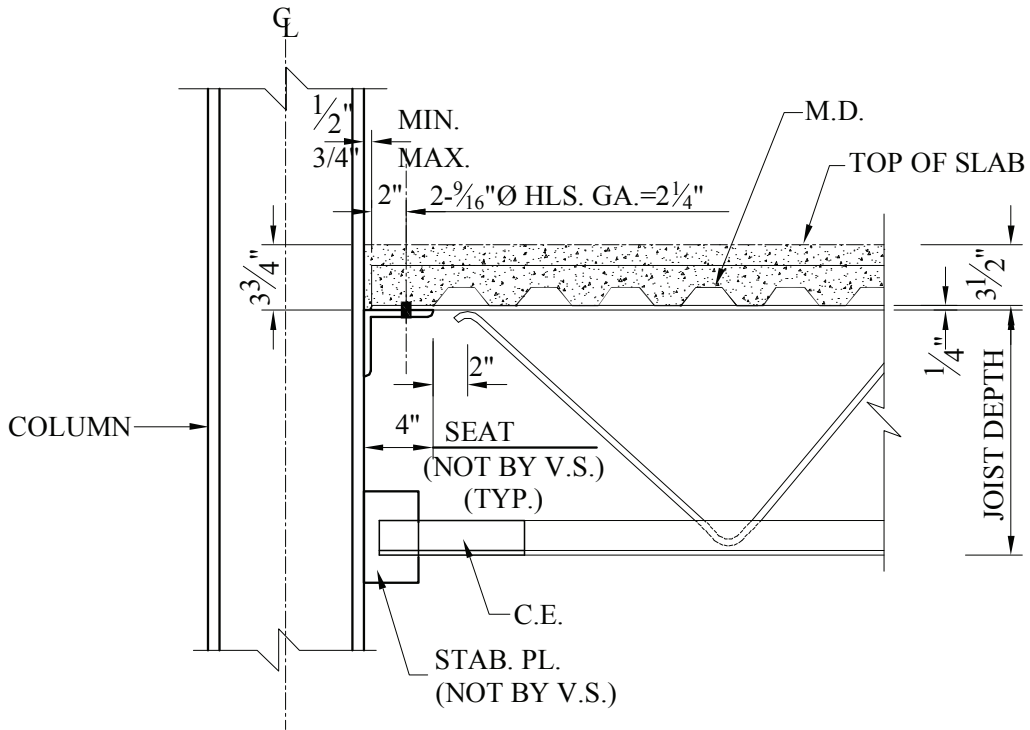

**JOIST CONNECTION TO COLUMN (WEB) 2 BOLTS DETAIL 18**

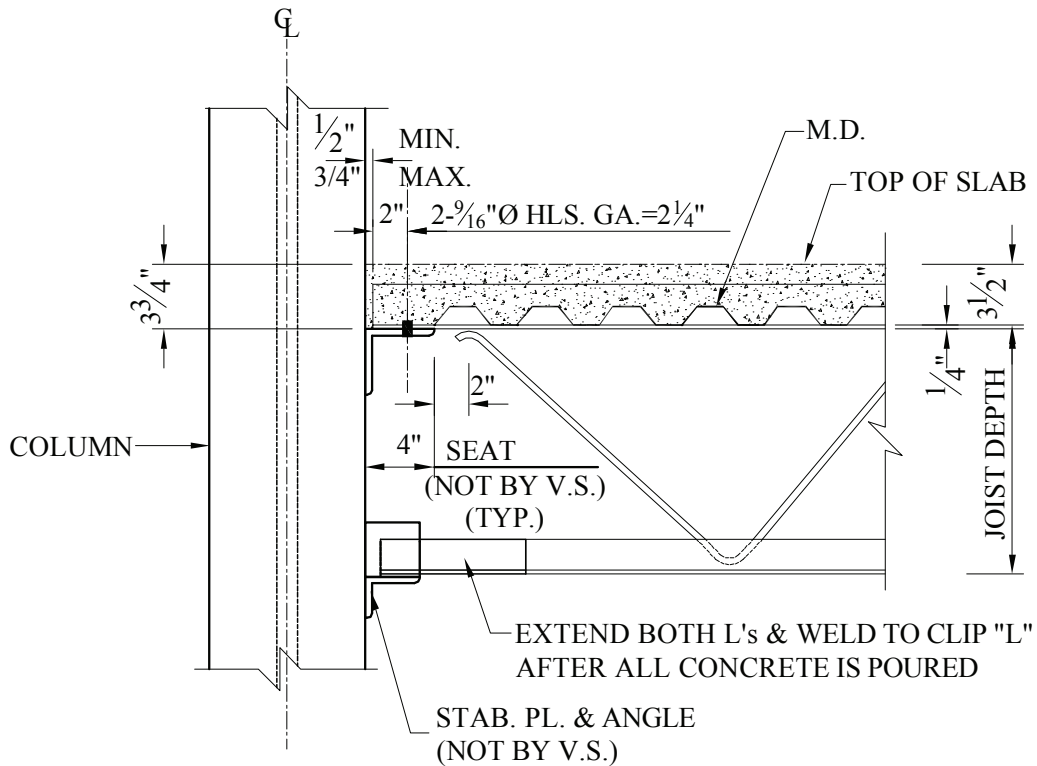

**JOIST BOLTED TO STEEL BEAM DETAIL 19**

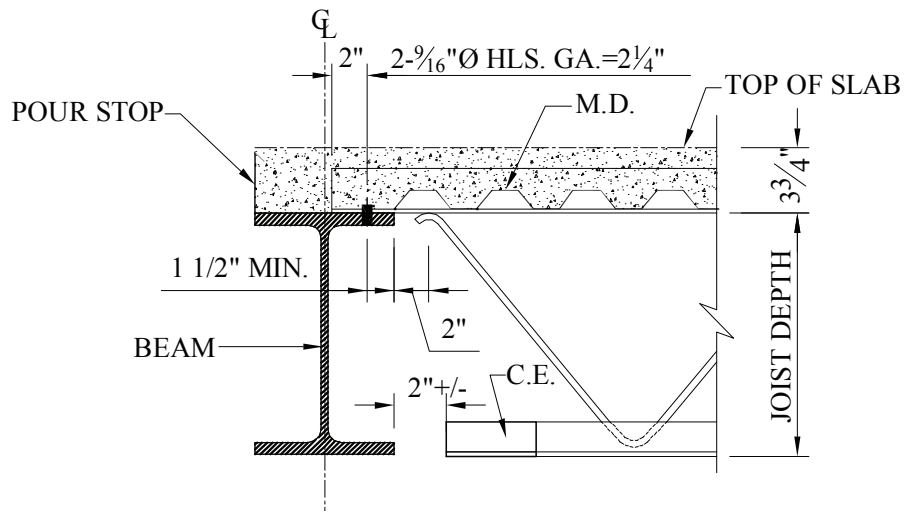

**JOIST MOMENT CONNECTION TO COLUMN (FLANGE) DETAIL 20**

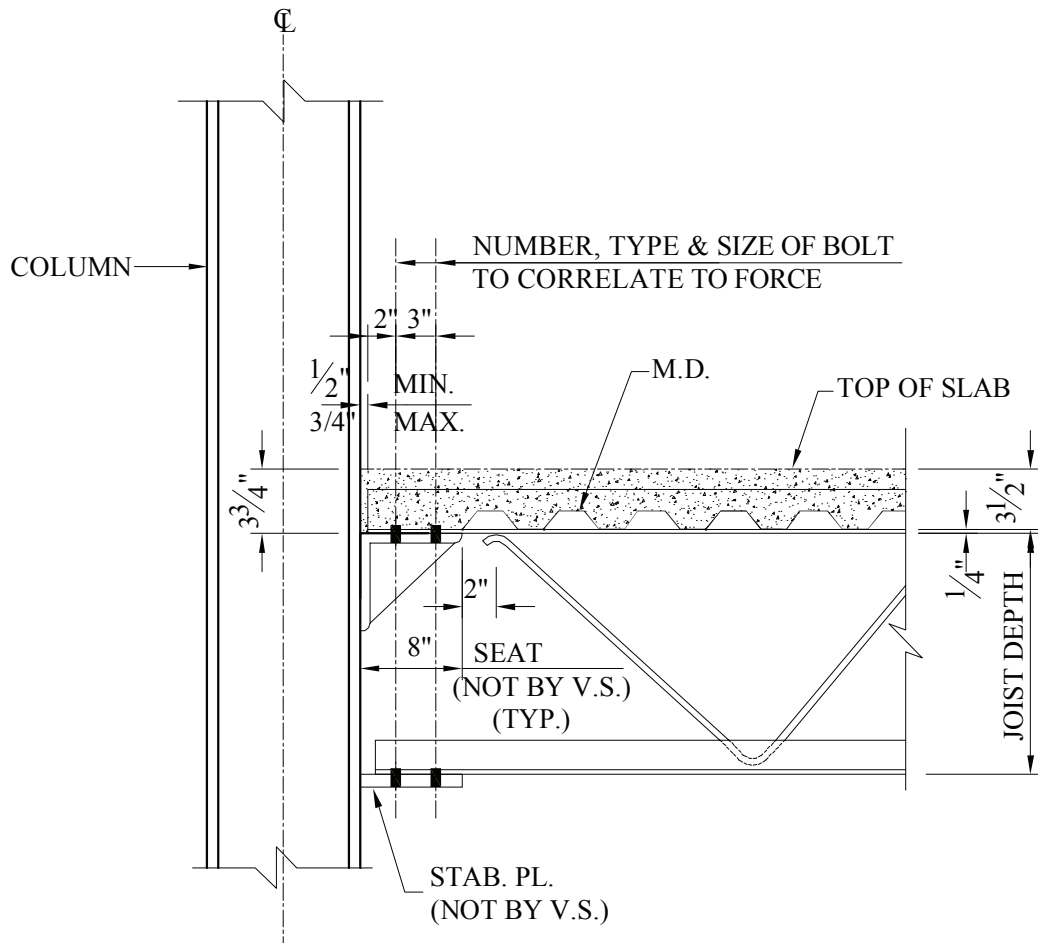

**JOIST MOMENT CONNECTION TO COLUMN (WEB) DETAIL 21**

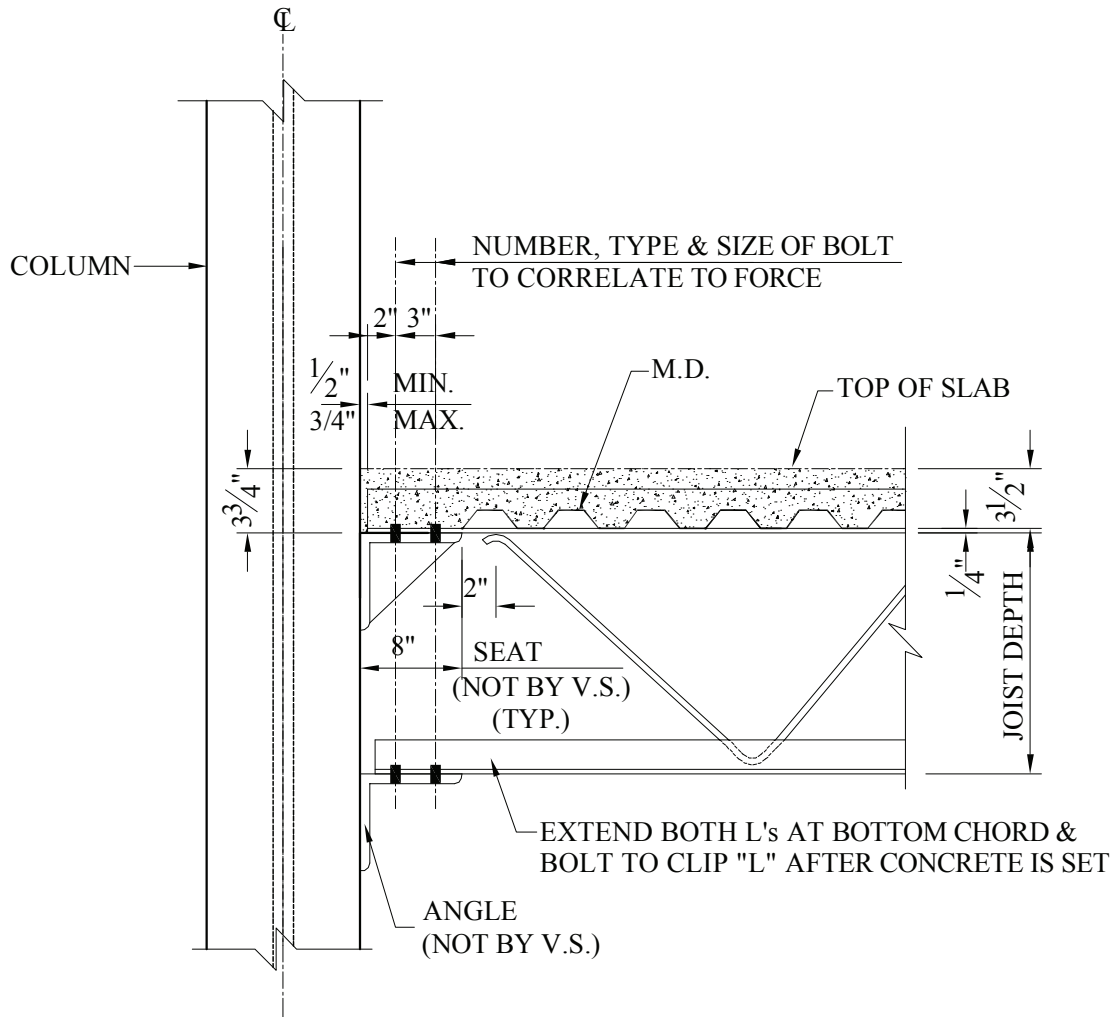

## Cantilevered Balcony (Joist Perpendicular to Balcony) DETAIL 22

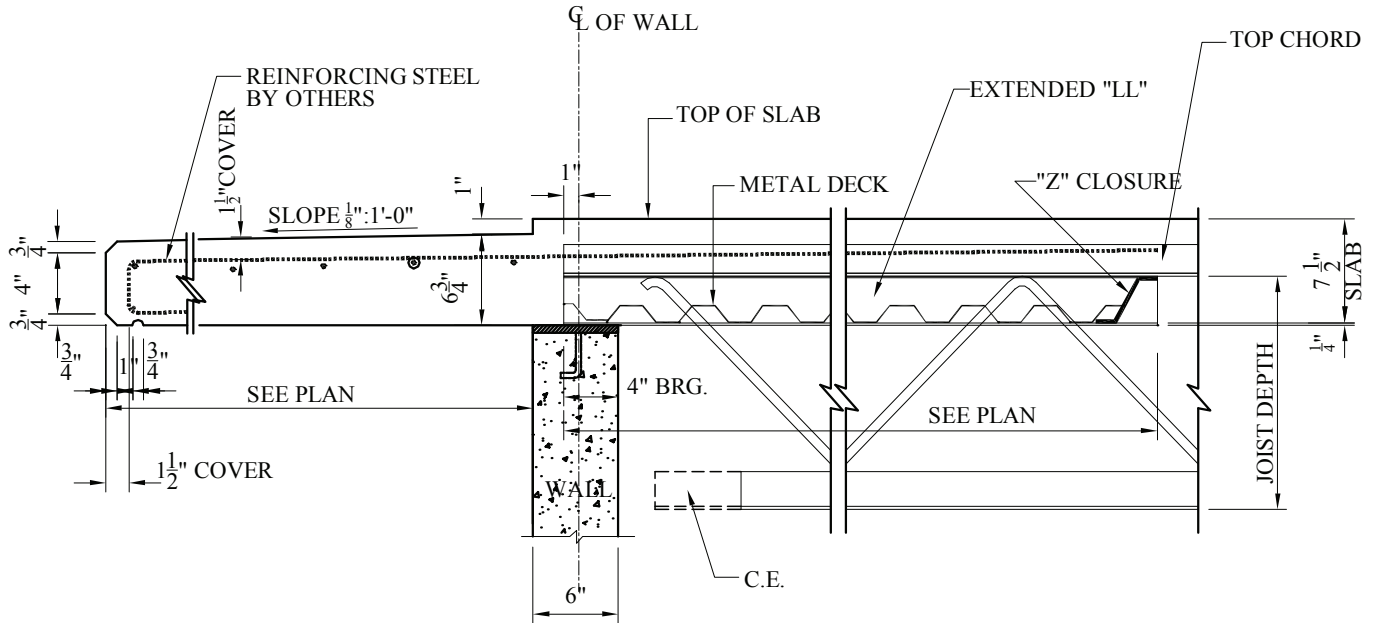

## Cantilevered Balcony (Joist Parallel to Balcony) DETAIL 23

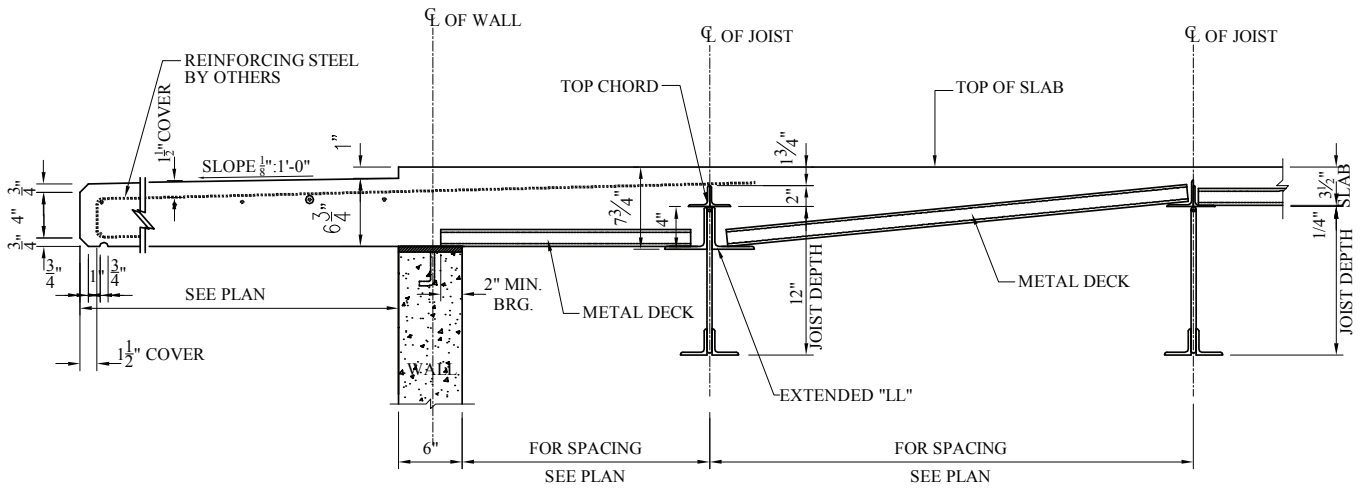

**VIERENDEEL OPENING TYPE A (LARGER BOTTOM CHORD) DETAIL 24**

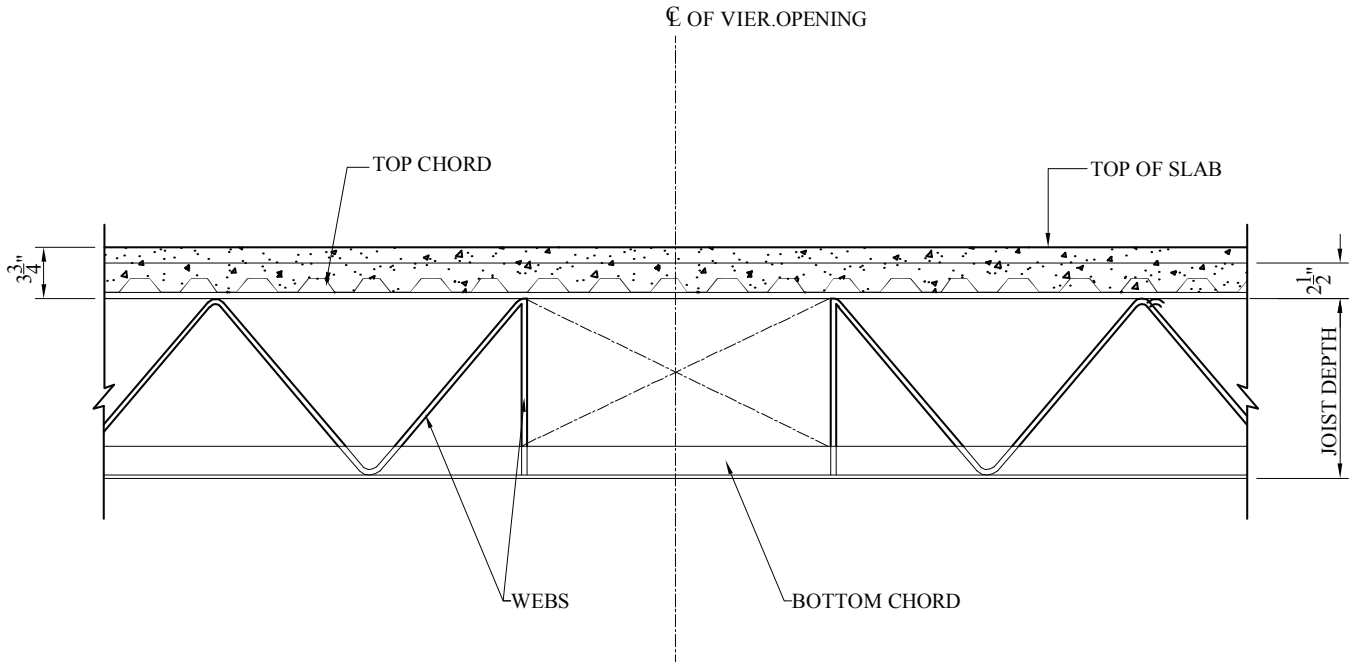

**VIERENDEEL OPENING TYPE B (REINFORCED BOTTOM CHORD) DETAIL 25**

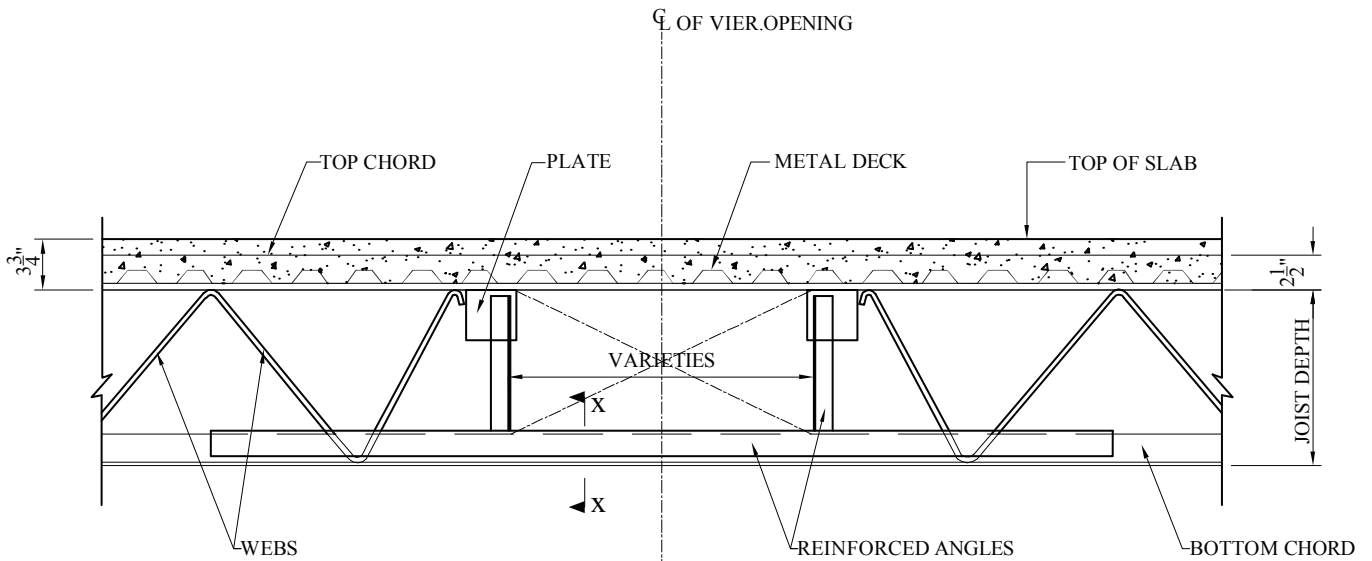

**JOISTS CONNECTION TO TRUSS GIRDER DETAIL 26**

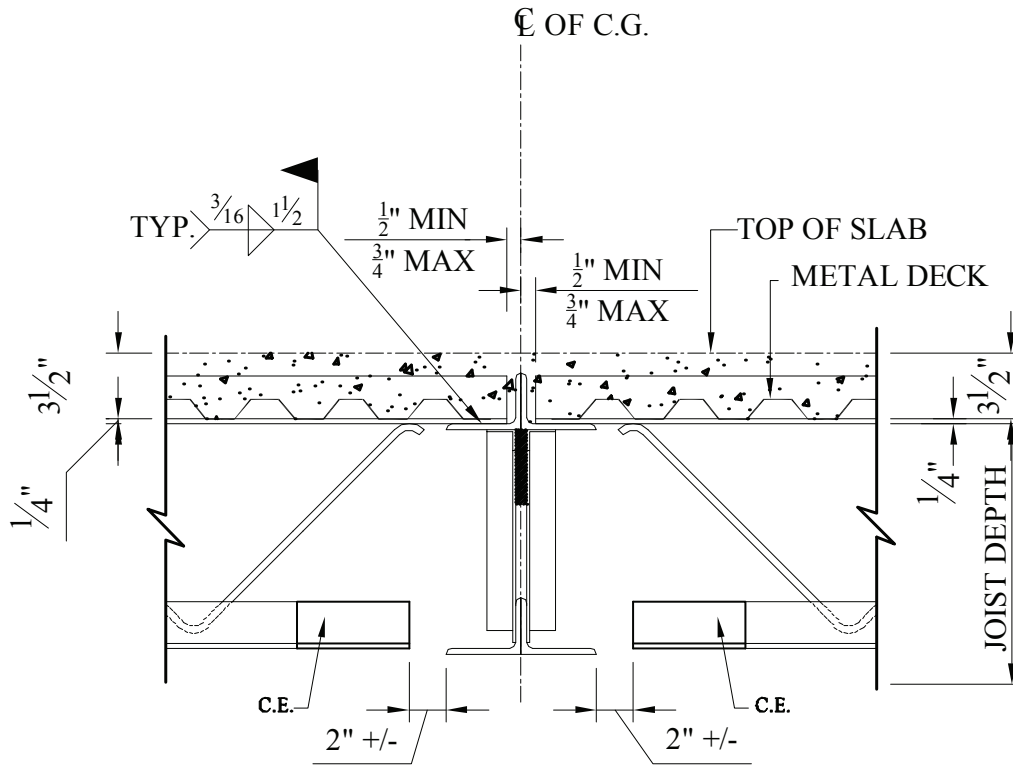

**JOISTS ON TRUSS GIRDER VIEW DETAIL 27**

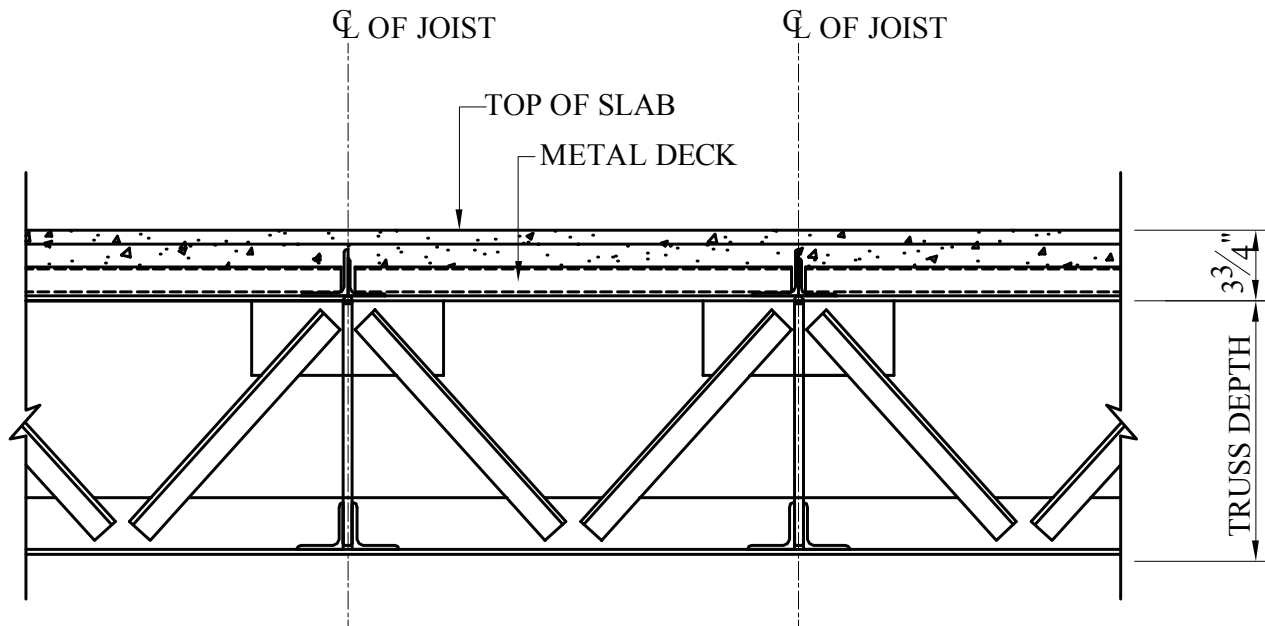

TRUSS GIRDER CONNECTION TO COLUMN FLANGE DETAIL 28

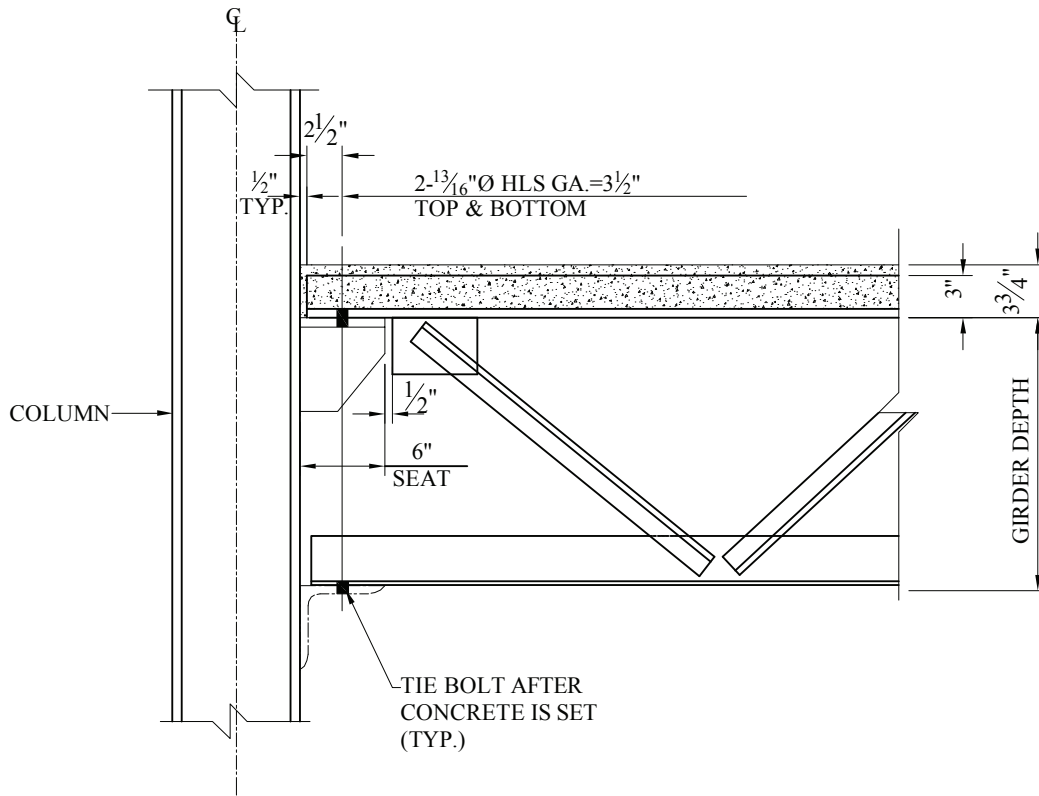

TRUSS GIRDER CONNECTION TO COLUMN WEB DETAIL 29

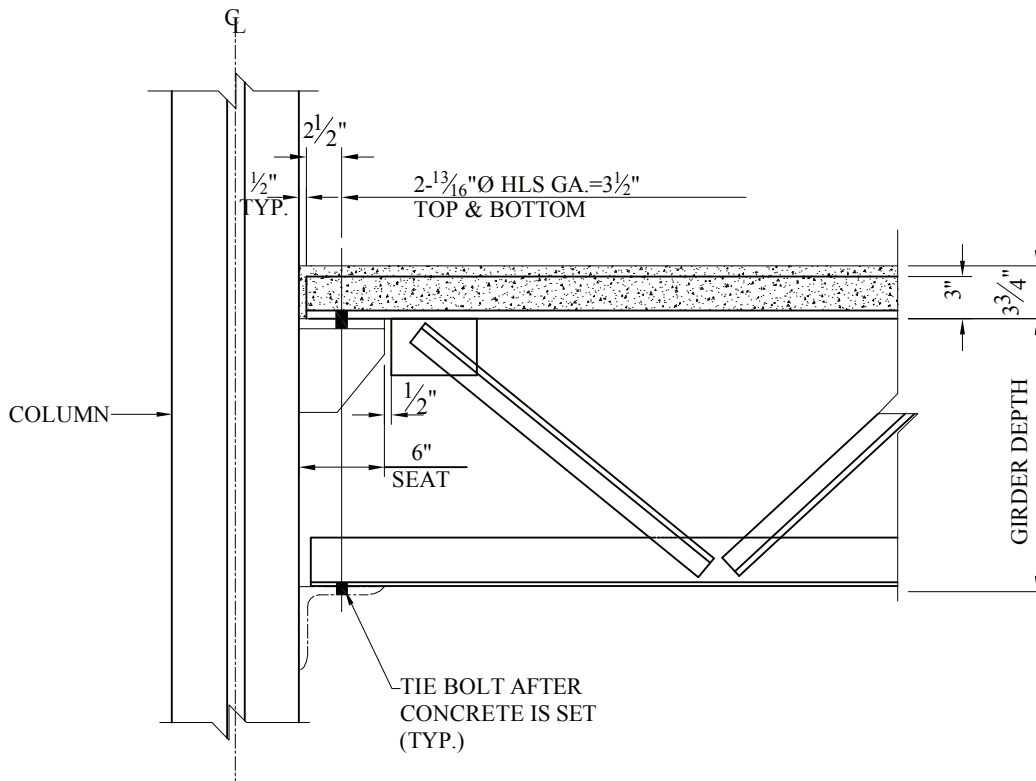

**MINIMUM EDGE OF SLAB TO ACHIEVE COMPOSITE ACTION DETAIL 30**

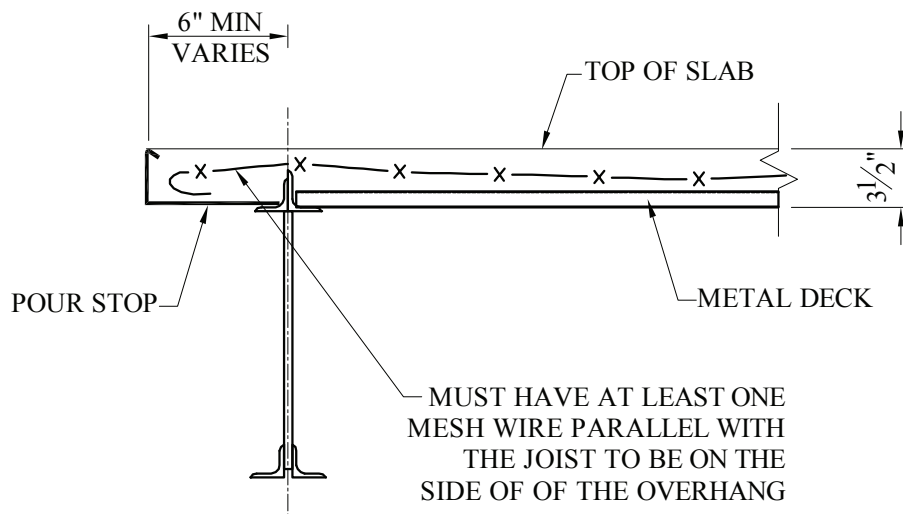

**OVERHANG WITH COMPOSITE JOIST PARALLEL TO SPANDREL BEAM DETAIL 31**

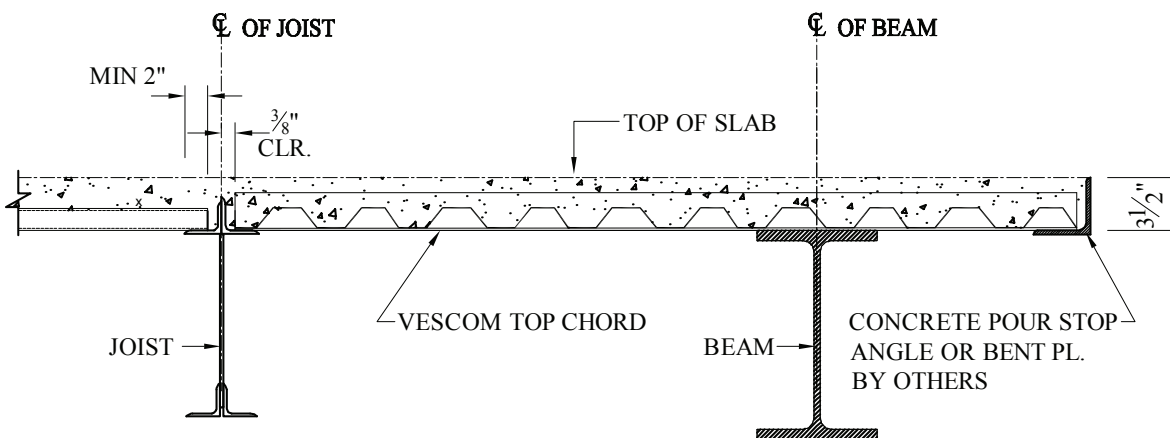

**COMPOSITE JOIST WITH EXTENDED TOP CHORD DETAIL 32**

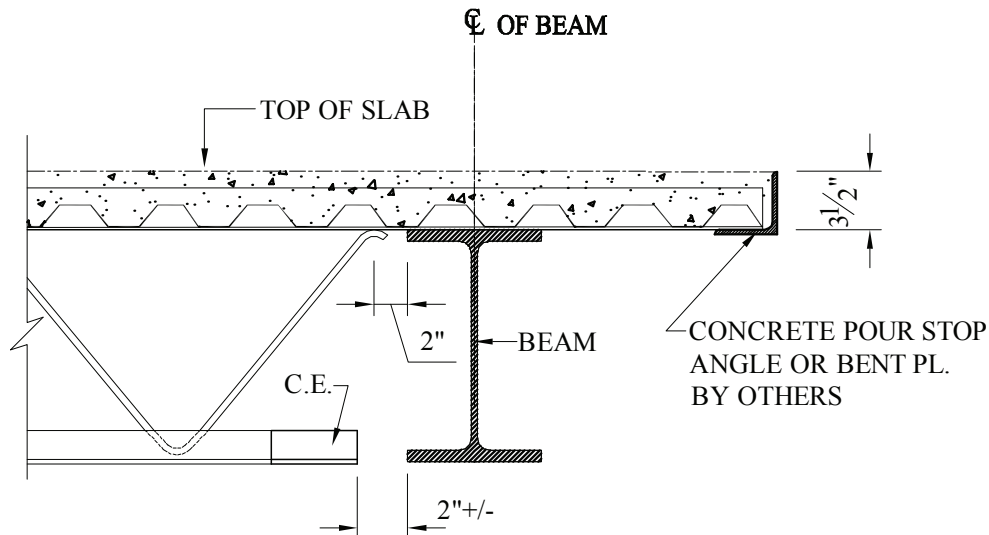



# CONTACT INFORMATION



Visit **CSCSteelUSA.com**  
for current details.

**Call Us, Toll Free**  
833-888-0545

## UNITED STATES PLANTS

### **ARIZONA** (Joist)

ᄁᄁᄁᄁ ᄁᄁᄁᄁ

22253 West Southern Avenue  
Buckeye, Arizona 85326  
Telephone: 623-386-1900

### **ILLINOIS** (Deck)

ᄁᄁᄁᄁ ᄁᄁᄁᄁ

9 Unytite Drive  
Peru, Illinois 61354  
Telephone: 815-224-9588

### **MISSOURI** (Joist)

ᄁᄁᄁᄁ ᄁᄁᄁᄁ

2000 West Main Street  
Washington, Missouri 63090-1008  
Telephone: 636-239-6716

### **FLORIDA** (Joist & Deck)

ᄁᄁᄁᄁ ᄁᄁᄁᄁ

140 Ellis Road South  
Jacksonville, Florida 32254  
Telephone: 904-781-0898  
Toll-free: 1-888-781-0898

### **MARYLAND** (Joist)\*

ᄁᄁᄁᄁ ᄁᄁᄁᄁ

4010 Clay Street, PO Box 285  
Point of Rocks, Maryland 21777-0285  
Telephone: 301-874-5141  
Toll-free: 1-800-638-4293

### **NEW JERSEY** (Deck)\*

ᄁᄁᄁᄁ ᄁᄁᄁᄁ

14 Harmich Road  
South Plainfield, New Jersey 07080  
Telephone: 908-561-3484  
Toll-free: 1-800-631-1215

\*Vescom Fabrication Locations

